

Features

- Supports multi-rate (100GBASE-100GE and OTU4); from 103.1Gb/s to 111.8Gb/s aggregate; Lane bit rate 25.78 Gb/s 100GE, 27.95 Gb/s OTU4;
- Up to 40km transmission on SMF;
- LAN WDM EML laser and PIN receiver with SOA; High speed I/O electrical interface (CAUI-10);
- MDIO interface with integrated Digital Diagnostic monitoring; CFP MSA package with duplex LC connector;
- Single +3.3V power supply;
- Maximum power consumption 16W;
- Operating case temperature: -5 to +70 °C;
- Complies with IEEE802.3ba and ITU-T G.959
- Complies with EU Directive 2011/65/EU (RoHS 6/6);

Application

- 100GBASE-ER4;

Order Information

Table 1- order information

Part No.	Data Rate	Laser	Fiber Type	Distance	Optical Interface	Temp	DDMI
HOLS-CFPLW40-LD-CE	103.1Gbps 111.8Gbps	1310nm EML	SMF	40km	LC	-5~70C	Y

Absolute Maximum Ratings

Table 2-Absolute Maximum Ratings

Parameter	Symbol	Min.	Typical	Max.	Unit	Notes
Storage Temperature	T _s	-40	-	+85	°C	
Supply Voltage	V _{CC}	-0.5	-	+4.0	V	
Operating Relative Humidity	RH	-	-	+85	%	

Recommended Operating Conditions

Table 3-Recommended Operating Conditions

Parameter	Symbol	Min.	Typical	Max.	Unit	Notes
Operating Case Temperature	T _c	-5	-	+70	°C	
Power Supply Voltage	V _{CC}	3.13	3.3	3.47	V	
Power Supply Current	I _{CC}	-	-	5	A	
Maximum Power Dissipation	P _D	-	-	16	W	
Aggregate Bit Rate	BR _{AVE}	-	103.125	-	Gb/s	
Lane Bit Rate	BR _{LANE}	-	25.78	-	Gb/s	
Transmission Distance	TD		-	40	km	Over SMF

Optical Characteristics

Table 4-Optical Characteristics

Transmitter

Parameter	Symbol	Min.	Typical	Max.	Unit	Notes
Center Wavelength Lane 0	λ_0	1294.53	1295.56	1296.59	nm	
Center Wavelength Lane 1	λ_1	1299.02	1300.05	1301.09	nm	
Center Wavelength Lane 2	λ_2	1303.54	1304.58	1305.63	nm	
Center Wavelength Lane 3	λ_3	1308.09	1309.14	1310.19	nm	
Total Launch Power, 100GE	P _{ALL}	-	-	8.9	dBm	1
Average Launch Power per Lane, 100GE	P _{TX_LANE}	-2.9	-	2.9	dBm	1
OMA per Lane, 100GE	OMA	0.1	-	4.5	dBm	1
OMA-TDP per Lane, 100GE	OMA_TDP	-	-	-	dBm	
Difference in launch power between lanes	P _{TX_DELTA_LANE}	-	-	3.6	dB	
Total Launch Output Power, OTU4	P _{ALL}	-	-	8.9	dBm	1
Average Launch Power per Lane, OTU4	P _{TX_LANE}	-2.9	-	2.9	dBm	1
Average Output Power (Laser Turn off)	P _{OUT-OFF}	-	-	-30	dBm	
Side Mode Suppression Ratio	SMSR	30	-	-	dB	
Extinction Ratio, 100GE	ER	8	-	-	dB	
Transmitter and Dispersion Penalty	TDP	-	-	3.5	dB	2
Optical Return Loss Tolerance	ORLT	-	-	20	dB	
Optical Eye Mask, 100GE	Compliant with IEEE 802.3ba					2
Optical Eye Mask, OTU4	Compliant with ITU-T G.959.1					2

Receiver

Parameter	Symbol	Min.	Typical	Max.	Unit	Notes
Center Wavelength Lane 0	λ_0	1294.53	1295.56	1296.59	nm	
Center Wavelength Lane 1	λ_1	1299.02	1300.05	1301.09	nm	
Center Wavelength Lane 2	λ_2	1303.54	1304.58	1305.63	nm	
Center Wavelength Lane 3	λ_3	1308.09	1309.14	1310.19	nm	
Average Rx Power per Lane, 100GE	P _{RX_LANE}	-20.9	-	4.5	dBm	3
OMA Sensitivity per Lane, 100GE	P _{OMA_LANE}	-	-	-21.4	dBm	3
Average Rx Power per Lane, OTU4	P _{RX_AVE_LANE}	-20.7	-	4.5	dBm	
Sensitivity per Lane, OTU4	P _{RX_AVE_LANE}	-	-	-23.2	dBm	4
Receiver Overload	P _{IN-OL}	4.5	-	-	dBm	
Reflectance	Ref	-	-	-26	dB	
LOS Assert per lane	LOS _A	-40	-	-	dBm	
LOS De-assert	LOS _D	-	-	-26	dBm	
LOS Hysteresis	LOS _H	0.5	-	6	dB	

Notes:

1. The optical power is launched into SMF.
2. Measured with a PRBS 2³¹-1 test pattern @25.78125/27.952 Gb/s, Hit ratio≤5E-5.
3. Measured with a PRBS 2³¹-1 test pattern @25.78125 Gb/s, BER≤1E-12.
4. Measured with a PRBS 2³¹-1 test pattern @27.952 Gb/s, BER≤1E-12(with FEC).

Electrical Characteristics

High-Speed Signal: Compliant to CAUI-10 (IEEE 802.3ba)

Low-Speed Signal: Compliant to CFP MSA Hardware Specification v 1.4

Table 5-Electrical Characteristics

Transmitter (Module Input)						
Parameter	Symbol	Min.	Typical	Max.	Unit	Notes
Differential Data Input Amplitude	$V_{IN,P-P}$	85	-	850	mVpp	
Differential Termination Mismatch		-	-	5	%	
Tx_Disable	Normal Operation	V_{IL}	-0.3	-	0.8	V
	Laser Disable	V_{IH}	2.0	-	$V_{CC}+0.3$	V
Receiver (Module Output)						
Parameter	Symbol	Min.	Typical	Max.	Unit	Notes
Differential Data Output Amplitude	$V_{OUT,P-P}$	200	-	760	mVpp	
Differential Termination Mismatch 1MHZ		-	-	5	%	
Output Rise/Fall Time, 20%~80%	T_R	12	-	-	ps	
Rx_LOS	Normal Operation	V_{OL}	-	-	0.2	V
	Lose Signal	V_{OH}	$V_{CC}-0.2$	-	-	V

Digital Diagnostics

Table 6-Digital Diagnostics

Parameter	Range	Accuracy	Unit	Calibration
Temperature	-5 to 70	± 3	$^{\circ}C$	Internal
Voltage	0 to V_{CC}	0.1	V	Internal
Tx Bias Current Per Lane	0 to 100	10%	mA	Internal
SOA Bias Current	0 to 130	10%	mA	Internal
Tx Output Power Per Lane	-3 to 3	± 3	dBm	Internal
Rx Power (Each Lane)	-25 to 5	± 3	dBm	Internal

Hardware Signal Pin Electrical Specification

Table 7-Reference 3.3V LVCOMS output/input termination

Reference MDIO Interface Termination

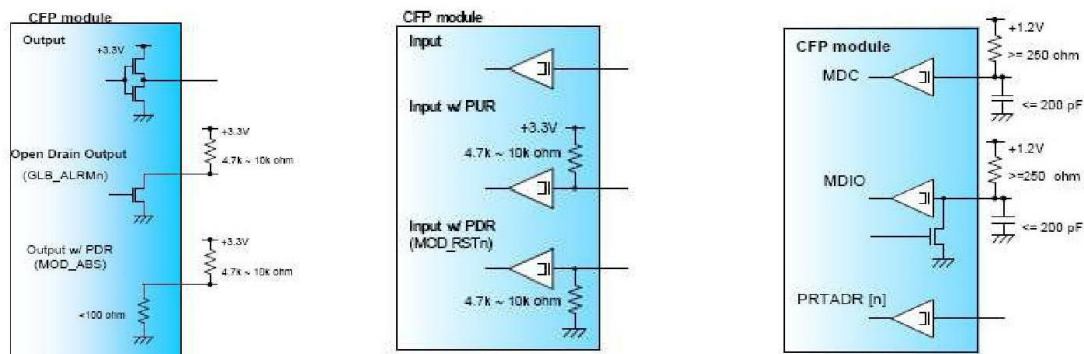

Note: The MSA recommends host termination resistor value of 560 Ohms, which provides the best balance of performance for both open-drain and active tri-state driver in the module.

Pin Definitions

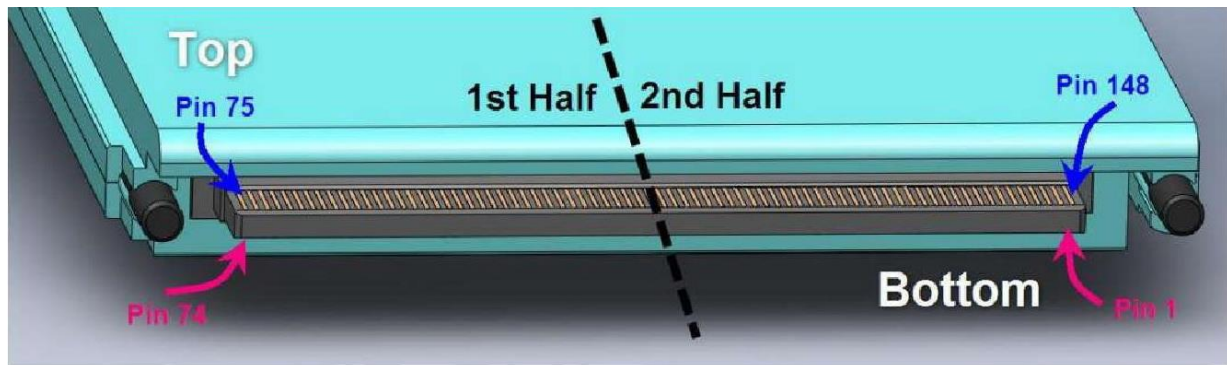
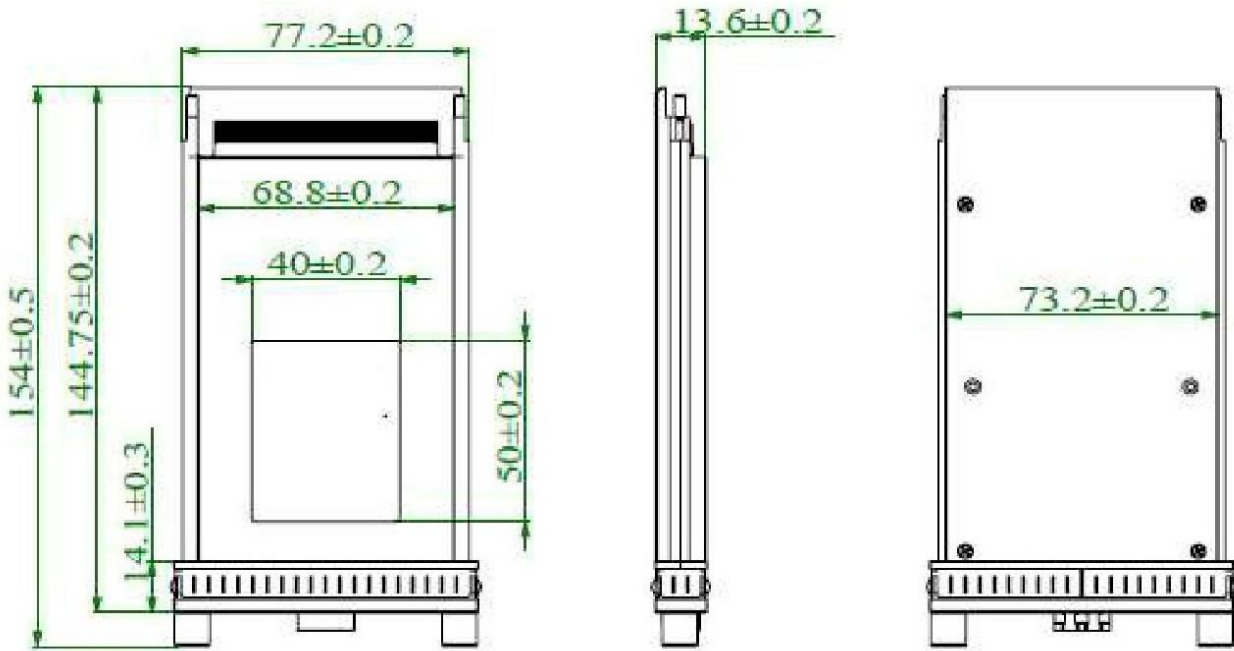

Table 8-Electrical Characteristics

	Top Row (2nd Half)		Bottom Row (2nd Half)		Top Row (1st Half)		Bottom Row (1st Half)	
148	GND	1	3.3V_GND		111	GND	38	MOD_ABS
147	REFCLKn	2	3.3V_GND		110	N.C.	39	MOD_RSTn
146	REFCLKp	3	3.3V_GND		109	N.C.	40	RX_LOS
145	GND	4	3.3V_GND		108	GND	41	GLB_ALRMn
144	N.C.	5	3.3V_GND		107	RX9n	42	PRTADR4
143	N.C.	6	3.3V		106	RX9p	43	PRTADR3
142	GND	7	3.3V		105	GND	44	PRTADR2
141	TX9n	8	3.3V		104	RX8n	45	PRTADR1
140	TX9p	9	3.3V		103	RX8p	46	PRTADR0
139	GND	10	3.3V		102	GND	47	MDIO
138	TX8n	11	3.3V		101	RX7n	48	MDC
137	TX8p	12	3.3V		100	RX7p	49	GND
136	GND	13	3.3V		99	GND	50	VND_IO_F
135	TX7n	14	3.3V		98	RX6n	51	VND_IO_G
134	TX7p	15	3.3V		97	RX6p	52	GND
133	GND	16	3.3V_GND		96	GND	53	VND_IO_H
132	TX6n	17	3.3V_GND		95	RX5n	54	VND_IO_J
131	TX6p	18	3.3V_GND		94	RX5p	55	3.3V_GND
130	GND	19	3.3V_GND		93	GND	56	3.3V_GND
129	TX5n	20	3.3V_GND		92	RX4n	57	3.3V_GND
128	TX5p	21	VND_IO_A		91	RX4p	58	3.3V_GND
127	GND	22	VND_IO_B		90	GND	59	3.3V_GND
126	TX4n	23	GND		89	RX3n	60	3.3V
125	TX4p	24	(TX_MCLKn)		88	RX3p	61	3.3V
124	GND	25	(TX_MCLKp)		87	GND	62	3.3V
123	TX3n	26	GND		86	RX2n	63	3.3V
122	TX3p	27	VND_IO_C		85	RX2p	64	3.3V
121	GND	28	VND_IO_D		84	GND	65	3.3V
120	TX2n	29	VND_IO_E		83	RX1n	66	3.3V
119	TX2p	30	PRG_CNTL1		82	RX1p	67	3.3V
118	GND	31	PRG_CNTL2		81	GND	68	3.3V
117	TX1n	32	PRG_CNTL3		80	RX0n	69	3.3V
116	TX1p	33	PRG_ALRM1		79	RX0p	70	3.3V_GND
115	GND	34	PRG_ALRM2		78	GND	71	3.3V_GND
114	TX0n	35	PRG_ALRM3		77	(RX_MCLKn)	72	3.3V_GND
113	TX0p	36	TX_DIS		76	(RX_MCLKp)	73	3.3V_GND
112	GND	37	MOD_LOPWR		75	GND	74	3.3V_GND

Mechanical Dimension



Warnings

Handling Precautions: This device is susceptible to damage as a result of electrostatic discharge (ESD). A static free environment is highly recommended. Follow guidelines according to proper ESD procedures. **Laser Safety:** Radiation emitted by laser devices can be dangerous to human eyes. Avoid eye exposure to direct or indirect radiation.