

FEATURES

- Single fiber bi-directional data links asymmetric TX 1244Mbps / RX 2488Mbps GPON ONU application with GPON MAC function.
- SC/UPC receptacle SFP with GPON ONU MAC inside, "Plug-and-play" via auto-discovery and configuration
- 1310nm DFB burst mode transmitter, 1490nm APD-TIA continuous mode receiver
- 0 to 70°C operating case temperature for HOLS-P3420345M-CT , C-Temp;
-40 to 85°C operating case temperature for HOLS-P3420345M-IT , I -Temp;
- Single 3.3V power supply
- Digital diagnostic monitor interface compatible with SFF-8472
- SFP MSA compliance
- Low EMI and excellent ESD protection
- Class I laser safety standard IEC-60825 compliant
- RoHS-6 compliance



APPLICATIONS

- Gigabit-capable Passive Optical Networks(GPON)
- HOLS-P3420345M-CT / HOLS-P3420345M-IT is an MSA-compliant SFP that incorporates not just the optics for an ONU, but all of the electronics need as well. It is a "PON on a Stick" that an entire FTTH ONU in a slightly oversized SFP. It can be plugged into networking equipment. Allowing the data interfaces on a switch, router, PBX, etc. to be customized for different fiber environments and distance requirements
- The HOLS-P3420345M-CT / HOLS-P3420345M-IT is designed as dual-mode ONU stick, it also supports the EPON ONU OAM.

It can be applied both on EPON system and on the GPON system .It will automatically establish an EPON link with the EPON OLT or GPON link with the GPON OLT.

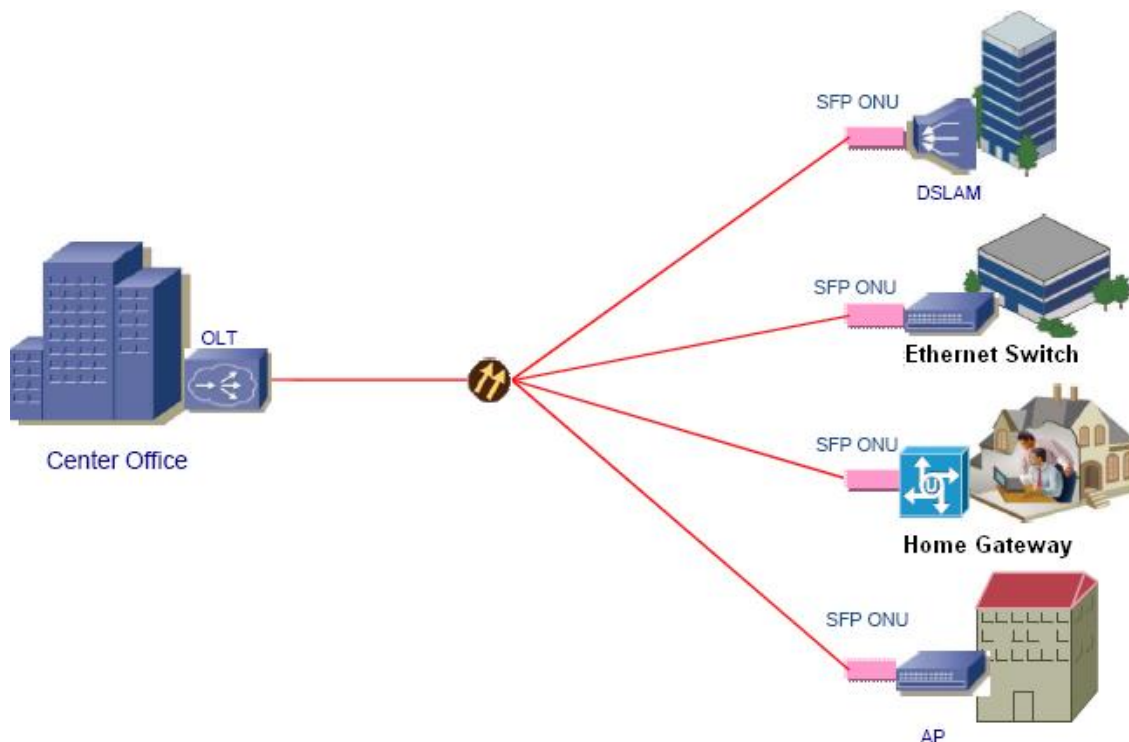

STANDARDS

- Complies with SFP Multi-Source Agreement (MSA) SFF-8074i
- Complies with ITUT-T G.984.2, G.984.2 Amendment 1
- Complies with ITUT G.988 ONU management and control interface (OMCI) specification
- Complies with SFF 8472 V9.5
- Complies with FCC 47 CFR Part 15, Class B

- Complies with FDA 21 CFR 1040.10 and 1040.11

ABSOLUTE MAXIMUM RATING

Parameter	Symbol	Min.	Max.	Unit	Notes
Storage Ambient Temperature	T _{STG}	-40	85	°C	
Operating Case Temperature	T _c	0	70	°C	HOLS-P3420345M-CT
	T _c	-40	85	°C	HOLS-P3420345M-IT
Operating Humidity	OH	5	95	%	
Power Supply Voltage	V _{CC}	-0.5	3.6	V	

RECOMMENDED OPERATING CONDITION

Parameter	Symbol	Min.	Typ.	Max.	Unit	Notes
Power Supply Voltage	V _{CC}	3.13	3.3	3.47	V	
Power Dissipation	PD	1.85	2.10	2.42	W	Max value under High temp environment
Operating Case Temperature	T _c	0		+70	°C	HOLS-P3420345M-CT
	T _c	-40		+85	°C	HOLS-P3420345M-IT
Operating Humidity Range	OH	5		95	%	
Data Rate			TX:1.244 / RX:2.488		Gbit/s	
Data Rate Drift		-100		+100	PPM	

TRANSMITTER OPTICAL CHARACTERISTICS

Parameter	Symbol	Min.	Typ.	Max.	Unit	Note
Optical Center Wavelength	λ_c	1290	1310	1330	nm	
Spectral Width (-20dB)	$\Delta\lambda$			1	nm	
Side Mode Suppression Ratio	SMSR	30			dB	
Average Launch Optical Power	AOP	0.5		5	dBm	Launched into SMF Fiber
Burst off Average Output Power				-45	dBm	
Extinction Ratio	ER	10			dB	
Rise/Fall Time (20%-80%)	T _R /T _F			0.26	ns	Unfiltered PRBS 2 ²³ -1 @1244.16Mbps
RIN ₁₅ OMA				-115	dB/Hz	
Optical Return Loss Tolerance		-15			dB	
Transmitter Reflectance				-10	dB	

Transmitter and Dispersion Penalty	TDP			1	dB	Transmit on 20km SMF.
Optical Waveform Diagram	Compliant With ITU-T G984.2			PRBS 2 ²³ -1 @1244.16Mbps		

TRANSMITTER ELECTRICAL CHARACTERISTICS

Parameter	Symbol	Min.	Typ.	Max.	Unit	Notes
Data Input Differential Swing		300		1800	mV	CML input, AC coupled
Input Differential Impedance		90	100	110	Ω	
Transmitter TxDisable Control Voltage -		0		0.8	V	
Transmitter TxDisable Voltage - High		2.0		V _{CC}	V	
Transmitter Fault Alarm Voltage - Low		0		0.4	V	
Transmitter Fault Alarm Voltage - High		2.4		V _{CC}	V	

RECEIVER OPTICAL CHARACTERISTICS

Parameter	Symbol	Min.	Typ.	Max.	Unit	Notes
Operating Wavelength	λ_c	1480	1490	1500	nm	
Sensitivity	SEN			-28	dBm	PRBS 2 ²³ -1 @2488.32Mbps
Saturation Optical Power	SAT	-8			dBm	
Loss of Signal De-Assert	LOSD			-29	dBm	
Loss of Signal Assert	LOSA	-40			dBm	
Signal-Detected Hysteresis		0.5		6	dBm	
Receiver Reflectance				-12	dB	$\lambda=1490\text{nm}$
WDM Filter Isolation		38			dB	$\lambda=1550\text{nm}$
		35			dB	$\lambda=1650\text{nm}$

RECEIVER ELECTRICAL CHARACTERISTICS

Parameter	Symbol	Min.	Typ.	Max.	Unit	Notes
Data Output Differential Swing		300		1200	mV	CML output, AC coupled
Loss of Signal - Low		0		0.4	V	
Loss of Signal - High		2.4		V _{CC}	V	

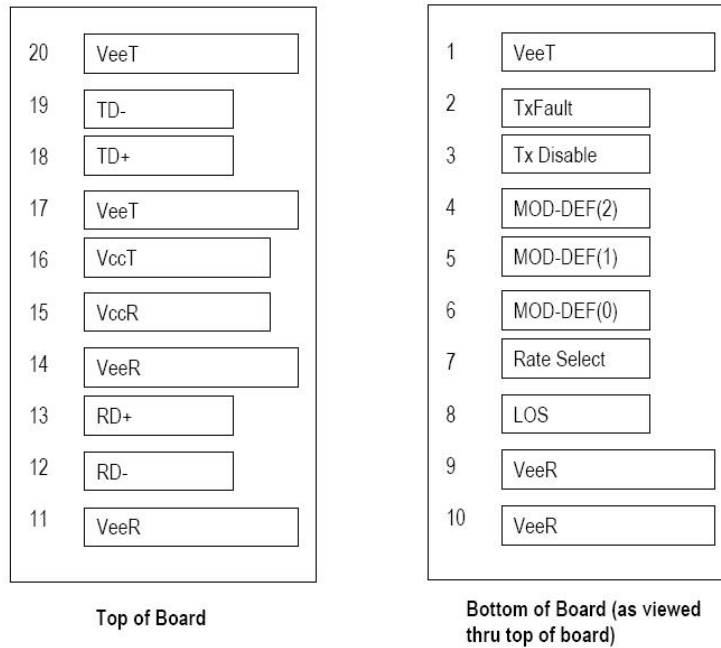

Figure 1 SFP Transceiver Electrical Pad Layout

PIN DESCRIPTION			
PIN	Name	Description	Notes
1	VeeT	Transmitter Ground	Note 5
2	TX Fault	Transmitter Fault Indication	Note 1
3	TX Disable	Transmitter Disable	Note 2, Module disables on high or open
4	MOD-DEF2	Module Definition 2	Note 3,2 wire serial ID Interface
5	MOD-DEF1	Module Definition 1	Note 3,2 wire serial ID Interface
6	MOD-DEF0	Module Definition 0	Note 3 Grounded in Module
7	Rate	NC	-
8	LOS	Loss of Signal	Note 4
9	VeeR	Receiver Ground	Note 5
10	VeeR	Receiver Ground	Note 5
11	VeeR	Receiver Ground	Note 5
12	RD-	Inv. Received DataOut	Note 6
13	RD+	Received Data Out	Note 6
14	VeeR	Receiver Ground	Note 5
15	VccR	Receiver Power	3.3 ±5%, Note 7
16	VccT	Transmitter Power	3.3 ±5%, Note 7
17	VeeT	Transmitter Ground	Note 5

18	TD+	Transmit Data In	Note 8
19	TD-	Inv.Transmit Data In	Note 8
20	VeeT	Transmitter Ground	Note 5

- TX Fault is an open collector/drain output, which should be pulled up with a 4.7K – 10K Ω resistor on the host board. Pull up voltage between 2.0V and VccT, R+0.3V. When high, output indicates a laser fault of some kind. Low indicates normal operation. In the low state, the output will be pulled to < 0.8V.
- TX disable is an input that is used to shut down the transmitter optical output. It is pulled up within the module with a 4.7 – 10K Ω resistor. Its states are:
 Low (0 – 0.8V): Transmitter on (>0.8, < 2.0V): Undefined
 High (2.0 – 3.465V): Transmitter Disabled Open: Transmitter Disabled
- Mod-Def 0,1,2. These are the module definition pins. They should be pulled up with a 4.7K – 10K Ω resistor on the host board. The pull-up voltage shall be VccT or VccR.
 Mod-Def 0 is grounded by the module to indicate that the module is present
 Mod-Def 1 is the clock line of two wire serial interface for serial ID Mod-Def 2 is the data line of two wire serial interface for serial ID
- LOS (Loss of Signal) is an open collector/drain output, which should be pulled up with a 4.7K – 10K Ω resistor. Pull up voltage between 2.0V and VccT, R+0.3V. When high, this output indicates the received optical power is below the worst-case receiver sensitivity (as defined by the standard in use). Low indicates normal operation. In the low state, the output will be pulled to < 0.8V.
- VeeR and VeeT may be internally connected within the SFP module.
- RD-/+ : These are the differential receiver outputs. They are AC coupled 100 Ω differential lines which should be terminated with 100 Ω (differential) at the user SERDES. The AC coupling is done inside the module and is thus not required on the host board. The voltage swing on these lines will be between 370 and 2000 mV differential (185 – 1000 mV single ended) when properly terminated.
- VccR and VccT are the receiver and transmitter power supplies. They are defined as 3.3V \pm 5% at the SFP connector pin. Maximum supply current is 300 mA. Recommended host board power supply filtering is shown below. Inductors with DC resistance of less than 1 Ω =should be used in order to maintain the required voltage at the SFP input pin with 3.3V supply voltage. When the recommended supply filtering network is used, hot plugging of the SFP transceiver module will result in an inrush current of no more than 30 mA greater than the steady state value. VccR and VccT may be internally connected within the SFP transceiver module.
- TD-/+ : These are the differential transmitter inputs. They are AC-coupled, differential lines with 100 Ω differential termination inside the module. The AC coupling is done inside the module and is thus not required on the host board. The inputs will accept differential swings of 500 – 2400 mV (250 – 1200 mV single-ended), though it is recommended that values between 500 and 1200 mV differential (250 – 600 mV single-ended) be used for best EMI performance.

Recommended Host Board Supply Filtering Network

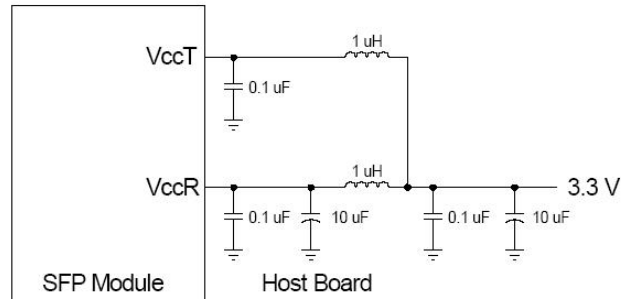

Figure 2 Recommended Host Board Supply Filtering Network

MECHANICAL SPECIFICATIONS

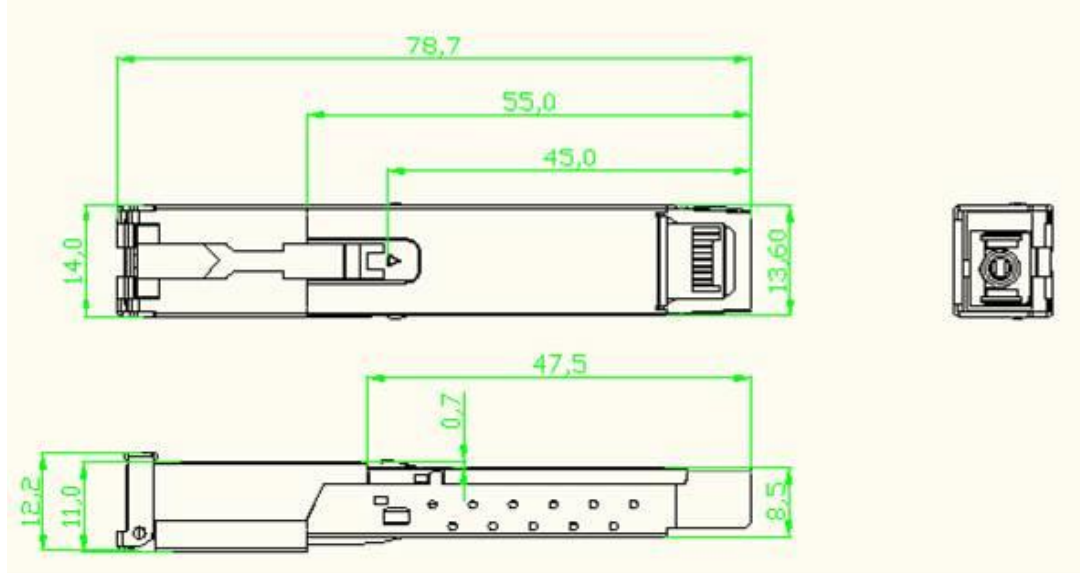

Figure 3 Mechanical Specifications

DESCRIPTION OF EEPROM ADDRESS A0H AND A2H

SFP ONU uses the two wire serial bus to access two blocks of 256-byte EEPROM address 1010000X (A0h) and 1010001X (A2h) , A0h stores static information including product and vendor IDs and A2h provides diagnostic information about the module's present operating conditions. The transceiver generates this diagnostic data by digitization of internal analog signals. Calibration and alarm/warning threshold data is written during device manufacture.

The below figure shows the detail descriptions of A0h and A2h. All this information is not only accessible by a local host equipment into which the EPON Stick is plugged, but also can be retrieved by OLT remotely through EPON OAM messages.

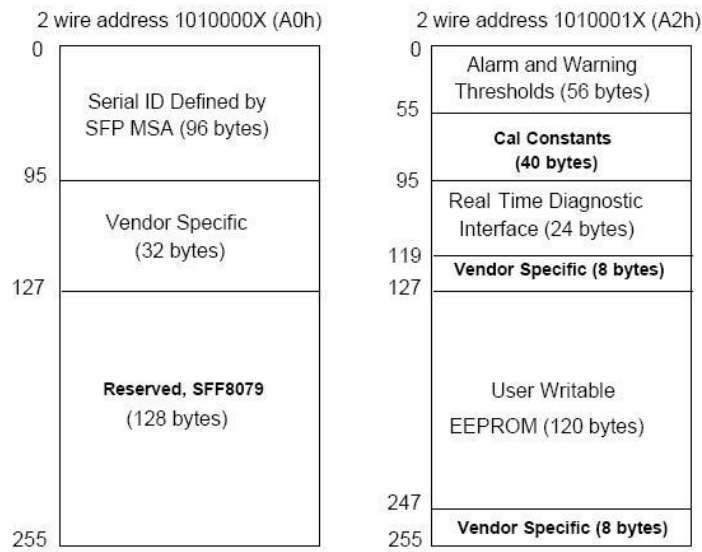

Figure 4 Detail descriptions of A0h and A2h defined by SFF-8472

EEPROM INFORMATION				
Data Addr	Field Size (Byte)	Name Of filed	Hex	Coded value
0(00)	1	Identifier	3	SFP
1(01)	1	Ext .Identifier	4	GBIC/SFP function is defined by serial ID only
2(02)	1	Connector	1	SC
3(03)	8	Transceiver (Noe 3)	0	
4(04)			0	
5(05)			0	
6(06)			80	BASE-PX
7(0X07)			0	
8(0X08)			0	
9(0X09)			0	
10(0X0A)			0	
11(0X0B)	1	Encoding	3	NRZ
12(0C)	1	BR, Nominal	D	1.25GHz
13(0D)	1	Reserved	0	
14(0E)	1	Length (9m)	14	20(km)
15(0F)	1	Length (9m)	C8	200(100m)
16(10)	1	Length (50um)	0	
17(11)	1	Length (62.5um)	0	

18(12)	1	Length (Copper)	0	
19(13)	1	Reserved	0	
20(14)	16	Vendor name	xx	H
21(15)			xx	O
22(16)			xx	N
23(17)			xx	L
24(18)			xx	U
25(19)			xx	S
26(1A)			xx	<space>
27(1B)			xx	T
28(1C)			xx	E
29(1D)			xx	C
30(1E)			xx	H
31(1F)			xx	O
32(20)			xx	I
33(21)			xx	O
34(22)			xx	G
35(23)			xx	Y
36(24)	1	Reserved	0	
37(25)	3	Vendor OUI	0	
38(26)			0	
39(27)			0	
40(28)	16	Vendor PN	xx	H
41(29)			xx	O
42(2A)			xx	L
43(2B)			xx	S
44(2C)			xx	-
45(2D)			xx	P
46(2E)			xx	3
47(2F)			xx	4
48(30)			xx	2
49(31)			xx	0
50(32)			xx	3
51(33)			xx	4
52(34)	xx	5		

53(35)			xx	M
54(36)			20	<space>
55(37)			20	<space>
56(38)	4	Vendor rev(Note 3)	31	1
57(39)			30	0
58(3A)			20	<space>
59(3B)			20	<space>
60(3C)	2	Wavelength	5	1310nm
61(3D)			1E	
62(3E)	1	Reserved	0	
63(3F)	1	CC_BASE	0	Note1
64(40)	2	Options	0	TX_FAULT, LOS
65(41)			0A	
66(42)	1	BR, max	0	
67(43)	1	BR, min	0	
68(44)	16	Vendor SN(Note 3)	FF	
69(45)			FF	
70(46)			FF	
71(47)			FF	
72(48)			FF	
73(49)			FF	
74(4A)			FF	
75(4B)			FF	
76(4C)			FF	
77(4D)			FF	
78(4E)			FF	
79(4F)			FF	
80(50)			FF	
81(51)			FF	
82(52)			FF	
83(53)			FF	
84(54)	8	Date code (Note 3)	00	Year
85(55)			13	Year
86(56)			00	Month
87(57)			05	Month

88(58)			00	Day
89(59)			31	Day
90(5A)			20	<Space>
91(5B)			20	<Space>
92(5C)	1	Diagnostic Monitoring Type	68	DD Implemented; Internally Calibrated; Average Power
93(5D)	1	Enhanced Options	B0	Optional Alarm/warning Flags Implemented;TX_FAULT;RX_LOS;
94(5E)	1	SFF-8472 Compliance	2	Rev 9.4of SFF-8472.
95(5F)	1	CC_EXT	FF	Note 2

- 1) The check code shall be the low order 8 bits of the sum of the contents of all the bytes from byte.
- 2) The check code shall be the low order 8 bits of the sum of the contents of all the bytes from byte 64 to byte 94, inclusive.
- 3) The value is reference date, it will be assigned accord to the module's actual situation

EEPROM INFORMATION(A2[127]=00H)

Data Address	Name Of filed	Description of field	Hex	Coded value
0(00)	Temp High Alarm	Temp High Alarm	64 / 55	100°C / 85°C
1(01)			00	(I Temp)/(C Temp)
2(02)	Temp Low Alarm	Temp Low Alarm	CE / F6	-50°C / -10°C
3(03)			00	(I Temp)/(C Temp)
4(04)	Temp High Warning	Temp High Warning	55 / 46	85°C / 70°C
5(05)			00	(I Temp)/(C Temp)
6(06)	Temp Low Warning	Temp Low Warning	D8 / 00	-40°C/ 0°C
7(07)			00	(I Temp)/(C Temp)
8(08)	Voltage High Alarm	Voltage High Alarm	8C	3.6V
9(09)			A0	
10(0A)	Voltage Low Alarm	Voltage Low Alarm	75	3V
11(0B)			30	
12(0C)	Voltage High Warning	Voltage High Warning	88	3.5V
13(0D)			B8	
14(0E)	Voltage Low Warning	Voltage Low Warning	79	3.1V
15(0F)			18	

16(10)	Bias High Alarm	Bias High Alarm	AF	90mA
17(11)			C8	
18(12)	Bias Low Alarm	Bias Low Alarm	0	0mA
19(13)			0	
20(14)	Bias High Warning	Bias High Warning	88	70mA
21(15)			B8	
22(16)	Bias Low Warning	Bias Low Warning	0	0mA
23(17)			0	
24(18)	TX Power High Alarm	TX Power High Alarm	8A	5.5dBm
25(19)			99	
26(1A)	TX Power Low Alarm	TX Power Low Alarm	2B	0.5dBm
27(1B)			D4	
28(1C)	TX Power High Warning	TX Power High Warning	7B	5dBm
29(1D)			87	
30(1E)	TX Power Low Warning	TX Power Low Warning	31	1dBm
31(1F)			2D	
32(20)	RX Power High Alarm	RX Power High Alarm	0C	-5dBm
33(21)			5A	
34(22)	RX Power Low Alarm	RX Power Low Alarm	0	-32dBm
35(23)			6	
36(24)	RX Power High Warning	RX Power High Warning	9	-6dBm
37(25)			D0	
38(26)	RX Power Low Warning	RX Power Low Warning	0	-31dBm
39(27)			8	
40(28)	Reserved	Reserved	0	
41(29)	Reserved	Reserved	0	
42(2A)	Reserved	Reserved	0	
43(2B)	Reserved	Reserved	0	
44(2C)	Reserved	Reserved	0	
45(2D)	Reserved	Reserved	0	
46(2E)	Reserved	Reserved	0	
47(2F)	Reserved	Reserved	0	
48(30)	Reserved	Reserved	0	
49(31)	Reserved	Reserved	0	
50(32)	Reserved	Reserved	0	

51(33)	Reserved	Reserved	0	
52(34)	Reserved	Reserved	0	
53(35)	Reserved	Reserved	0	
54(36)	Reserved	Reserved	0	
55(37)	Reserved	Reserved	0	
56(38)	Rx_PWR(4)	Polynomial Fit Coefficient of Order 4 for Rx Optical Power Calibartion.	0	0
57(39)			0	
58(3A)			0	
59(3B)			0	
60(3C)	Rx_PWR(3)	Polynomial Fit Coefficient of Order 3 for Rx Optical Power Calibartion.	0	0
61(3D)			0	
62(3E)			0	
63(3F)			0	
64(40)	Rx_PWR(2)	Polynomial Fit Coefficient of Order 2 for Rx Optical Power Calibartion.	0	0
65(41)			0	
66(42)			0	
67(43)			0	
68(44)	Rx_PWR(1)	Polynomial Fit Coefficient of Order 1 for Rx Optical Power Calibartion.	3F	1
69(45)			80	
70(46)			0	
71(47)			0	
72(48)	Rx_PWR(0)	Polynomial Fit Coefficient of Order 0 for Rx Optical Power Calibartion.	0	0
73(49)			0	
74(4A)			0	
75(4B)			0	
76(4C)	Tx_I(Slope)	Slope of Laser Bias Current Linear Calibartion	1	1
77(4D)			0	
78(4E)	Tx_I(Offset)	Offset of Laser Bias Current Linear Calibartion	0	0
79(4F)			0	
80(50)	Tx_PWR(Slope)	Slope of Transmitter Coupled Output Power Linear Calibartion	1	1
81(51)			0	
82(52)	Tx_PWR(Offset)	Offset of Transmitter Coupled Output Power Linear Calibartion	0	0
83(53)			0	
84(54)	T (Slope)	Slope of Temperature Linear Calibartion	1	1

85(55)			0	
86(56)	T (Offset)	Offset of Temperature Linear Calibartion	0	0
87(57)			0	
88(58)	V (Slope)	Slope of Supply Voltage Linear Calibartion	1	1
89(59)			0	
90(5A)	V (Offset)	Offset of Supply Voltage Linear Calibartion	0	0
91(5B)			0	
92(5C)	Reserved	Reserved	0	
93(5D)	Reserved	Reserved	0	
94(5E)	Reserved	Reserved	0	
95(5F)	CC_EXT	Check code for the Extended ID Fields (addresses 0 to 94)	FF	Note 1
96(60)			FF	
97(61)			FF	
98(62)			FF	
99(63)			FF	
100(64)			FF	
101(65)			FF	
102(66)			FF	
103(67)			FF	
104(68)			FF	
105(69)			FF	
106(6A)	unallocated		FF	
107(6B)	unallocated		FF	
108(6C)	unallocated		FF	
109(6D)	unallocated		FF	
110(6E)	TX_DISABLE_STATE	TX_DISABLE_STATE	00	-
	SOFT_TX_DISABLE	Enables direct control of the transmitter via I2C		Disable
	ROGUE_ONU	Set this bit to "1" on the occurrence of a rogue ONU condition. Set to "0" to reset.		-
	N/A			-
	ROGUE_TXP_LO_FL AG	Set to 1 when TXP_LO_FLAG has been seted in Rogue_TXP_LO_EN bit enable.		-
	TX_FAULT_STATE	TX_FAULT_STATE		-

	RX_LOS_STATE	RX_LOS_STATE		-
	DATA_READY_BAR_STATE	Indicates GN25L95 has achieved power and data is ready.Bit stays high until data is ready at which time the GN25L95 sets this bit low		-
111(6F)	N/A		40	-
	TX_FAST_SLEEP	Default "0" means on de-assert of TX_SLEEP,Tx implements a reset start.Set to "1" enable the Tx to use the last known bias & mod values.		Set to "1" enable the Tx to use the last known bias & mod values.
	RX_SLEEP_ASSERT	Set to 1 enable RX_SLEEP mode		disable
	RX_SLEEP_STATE	RX_SLEEP_STATE		-
	TX_SLEEP_STATE	TX_SLEEP_STATE		-
	POW_LEV	Sets the GPON power leveling control		00=0dB
112(70)	Alarm_flags1	alarm & warning flags	00	00
113(71)	Alarm_flags2	alarm & warning flags	00	00
114(72)	Rogue ONU Timer Setup	Sets the interval time for counters located at 78h and 79h.4 vaules are avialable.80h=40ms,40h=80ms,20h=160ms,10h=320ms.	80	set as 80h=40ms
	Reserved			
115(73)	Reserved		FF	
116(74)	Warning_flag1	alarm & warning flags	00	00
117(75)	Warning_flag2	alarm & warning flags	00	00
118(76)	Reserved		FF	
119(77)	unallocated		FF	
120-255	Reserved	Reserved for debug information		

DIGITAL DIAGNOSTIC MONITORING INTERFACE

Parameter	Range	Accuracy	Calibration
Temperature	-40 to 85°C (I Temp)	±3°C	Internal
	0 to 70°C (C-Temp)	±3°C	

Voltage	0 to 3.7V	±3%	Internal
Bias Current	0 to 130mA	±10%	Internal
Burst TX Power	-10 to 58dBm	±2dB	Internal
RX Power monitor	-34to -8dBm	±2dB	Internal

WARNINGS

- Handling Precautions: This device is susceptible to damage as a result of electrostatic discharge (ESD). A static free environment is highly recommended. Follow guidelines according to proper ESD procedures.
- Laser Safety: Radiation emitted by laser devices can be dangerous to human eyes. Avoid eye exposure to direct or indirect radiation.