

### Features:

- Compliant with SFP MSA standard
- 3.3V DC power supply
- 1550nm DFB, 1250Mbps, 110km
- Difference LVPECL inputs and outputs
- Duplex LC connector
- Compliant with SFF-8472
- Hot Pluggable
- ROHS compliant



### Application:

- Fast Ethernet data link
- Data storage networks
- Other optical links
- Optical access network

### Description

Honlus 1250Mbps single-mode SFP is a high performance and cost effective transceiver. It is designed to meet Fast Ethernet application. The transceiver consists two sections: the transmitter section consists of a high reliability 1550nm DFB laser diode (LD) with monitor photo detector (PD) in eye safety; the receiver section consists of a high-speed APD and trans-impedance preamplifier. The output of the APD drives the post-amplification, quantizing, and optical signal detection circuits. The receiver is equipped with the LOS monitoring function. For further information, please see SFP MSA and SFF-8472 standard.

### Block Diagram

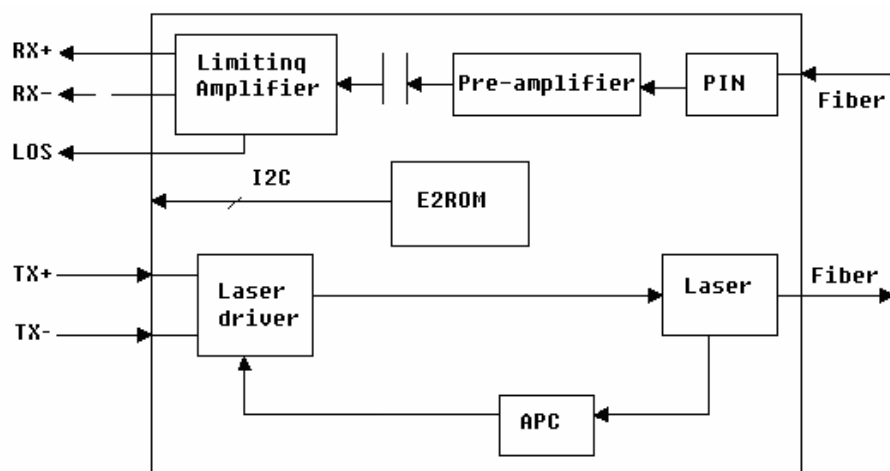

### PECL Logic Level

Logic State	Unit	Min	Typ	Max
Low	V	VCC-1.84	-	VCC-1.60
High	V	VCC-1.10	-	VCC-0.90

### TTL Logic Level

Logic State	Unit	Min	Typ	Max
Low	V	0	-	0.8
High	V	2.4	-	VCC

### Transceiver Pin Locations

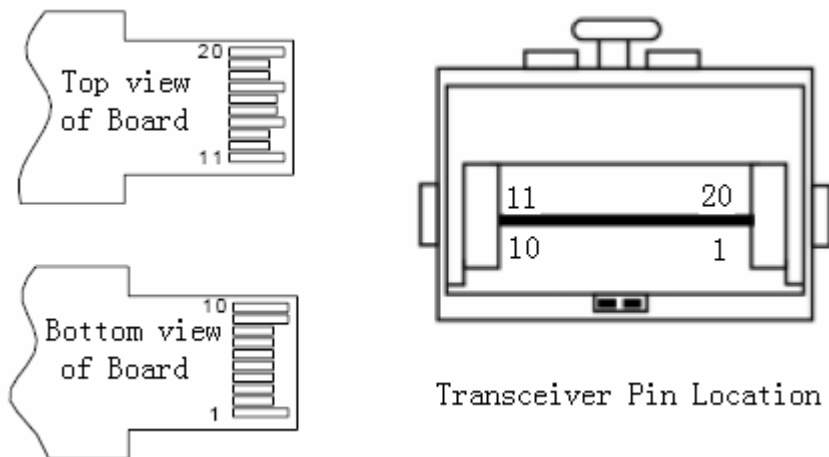

### Pin Descriptions

Pin	Name	Description	Plug Sequence	Note
1	VeeT	Transmitter Ground	1	
2	TX Fault	Transmitter Fault Indication	3	1
3	TX Disable	Transmitter Disable	3	2

4	MOD_DEF2	Module Definition 2	3	3
5	MOD_DEF1	Module Definition 1	3	3
6	MOD_DEF0	Module Definition 0	3	3
7	Rate Select	Not Connected	3	
8	LOS	Loss of Signal	3	4
9	VeeR	Receiver Ground	1	
10	VeeR	Receiver Ground	1	
11	VeeR	Receiver Ground	1	
12	RD-	Inverse Received Data Out	3	5
13	RD+	Received Data Out	3	5
14	VeeR	Receiver Ground	1	
15	VccR	Receiver Power	2	
16	VccT	Transmitter Power	2	
17	VeeT	Transmitter Ground	1	
18	TD+	Transmit Data In	3	6
19	TD-	Inverse Transmit Data In	3	6
20	VeeT	Transmitter Ground	1	

Note:

- 1, TX Fault is an open collector output, which should be pulled up with a 4.7k~10k\_ resistor on the host board to a voltage between 2.0V and Vcc+0.3V. Logic 0 indicates normal operation; logic 1 indicates a laser fault of some kind. In the low state, the output will be pulled to less than 0.8V.
2. TX Disable is an input that is used to shut down the transmitter optical output. It is pulled up within the module with a 4.7k~10k\_ resistor. Its states are:  
 Low (0~0.8V): Transmitter on (>0.8V, <2.0V): Undefined  
 High (2.0~3.465V): Transmitter Disabled  
 Open: Transmitter Disable
3. MOD-DEF 0, 1, 2 are the module definition pins. They should be pulled up with a 4.7k~10k\_ resistor on the host board. The pull-up voltage shall be VccT or VccR.  
 MOD-DEF 0 is grounded by the module to indicate that the module is present  
 MOD-DEF 1 is the clock line of two wire serial interface for serial ID  
 MOD-DEF 2 is the data line of two wire serial interface for serial ID
4. LOS is an open collector output, which should be pulled up with a 4.7k~10k\_ resistor on the

- host board to a voltage between 2.0V and  $V_{CC}+0.3V$ . Logic 0 indicates normal operation; logic 1 indicates loss of signal. In the low state, the output will be pulled to less than 0.8V.
5. These are the differential receiver outputs. They are AC-coupled 100\_ differential lines which should be terminated with 100\_ (differential) at the user SERDES.
  6. These are the differential transmitter inputs. They are AC-coupled, differential lines with 100\_ differential termination inside the module.

### Absolute Maximum Ratings

Parameter	Symbol	Min	Max	Unit
Storage Temperature	$T_S$	-40	85	$^{\circ}C$
Operation Temperature	$T_o$	0	70	$^{\circ}C$
Storage Relative Humidity	$RH_S$	-	95	%
Power Supply	VCC	-	5.5	V
Lead Solder Temperature	$T_{SLD}$	-	260	$^{\circ}C$
Lead Solder Duration	$t_{SLD}$	-	10	s
Voltage on any input/output pin	$V_{IO}$	0	VCC	V

### Performance Specification

Transmitter Electro-Optical Characteristics						
Parameter	Symbol	min	Typ	Max	Unit	Note
Supply Voltage	VCC	3.15	3.3	3.45	V	
Operation Current	$I_{CC}$	-	-	130	mA	
Differential Input Voltage	$V_{IN}$	400	-	1600	mV	
Data Rate	Rate	-	1250	-	Mbps	
Optical Output Power	$P_o$	0	-	5	dBm	
Extinction Ratio	ER	8.2	-	-	dB	
Central Wavelength	$\lambda_{DFB}$	1500	1550	1600	nm	
Output Spectrum Width	$\Delta\lambda/DFB$	-	-	1	nm	-20dB Width

Optical Rise Time	$T_r$	-	-	0.26	ns	20%~80%
Optical Fall Time	$T_f$	-	-	0.26	ns	20%~80%
Eye Diagram	Compliant IEEE802.3z					

Receiver Electro-Optical Characteristics						
Parameter	Symbol	min	Typ	Max	Unit	Note
Differential Output Voltage	$V_{OUT}$	500	-	1200	mV	1
Data Rate	Rate	-	1250	-	Mbps	
Receiver Sensitivity	S	-	-34	-30	dBm	2
Optical Input Overload	$P_{OL}$	-8	-	-	dBm	
Operating Central Wavelength	$\lambda$	1100	-	1600	nm	
SD (Signal Detected)	Optical Decreased	-45	-	-	dBm	
	Optical Increased	-	-	-30	dBm	
SD Hysteresis	$P_H$	0.5		5	dB	

Note 1: Internally AC coupled.

Note 2: Average received power where the BER =  $10^{-12}$ , measured with a 27-1 NRZ test pattern..

## Power Supply

The Transceiver includes internal circuit components to filter power supply noise. Under some conditions of EMI and power supply noise, external power supply filtering may be necessary. If receiver sensitivity is found to be degraded by power supply noise, the filter network illustrated in the following figure may be used to improve performance. The values of the filter components are general recommendations and may be changed to suit a particular system environment. Shielded inductors are recommended.

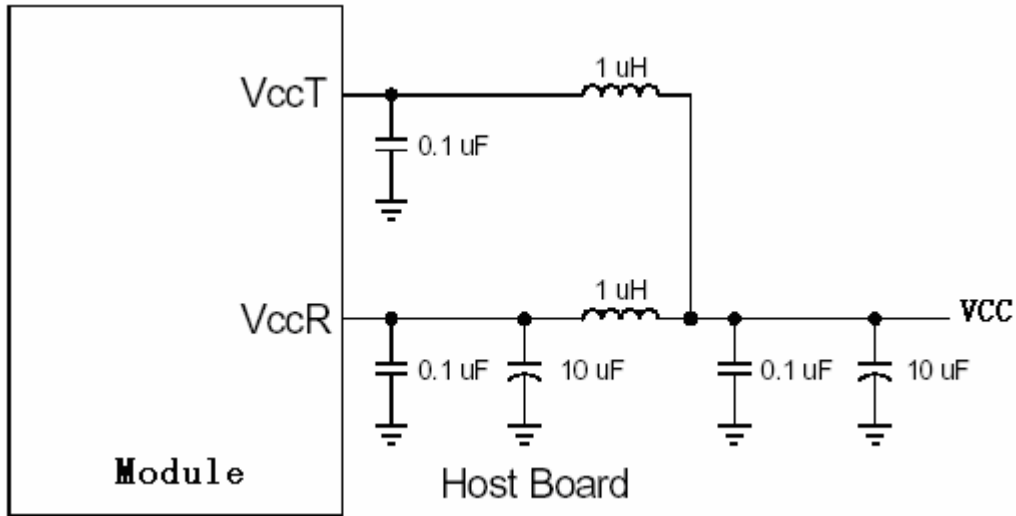

**Recommended Application Circuits**

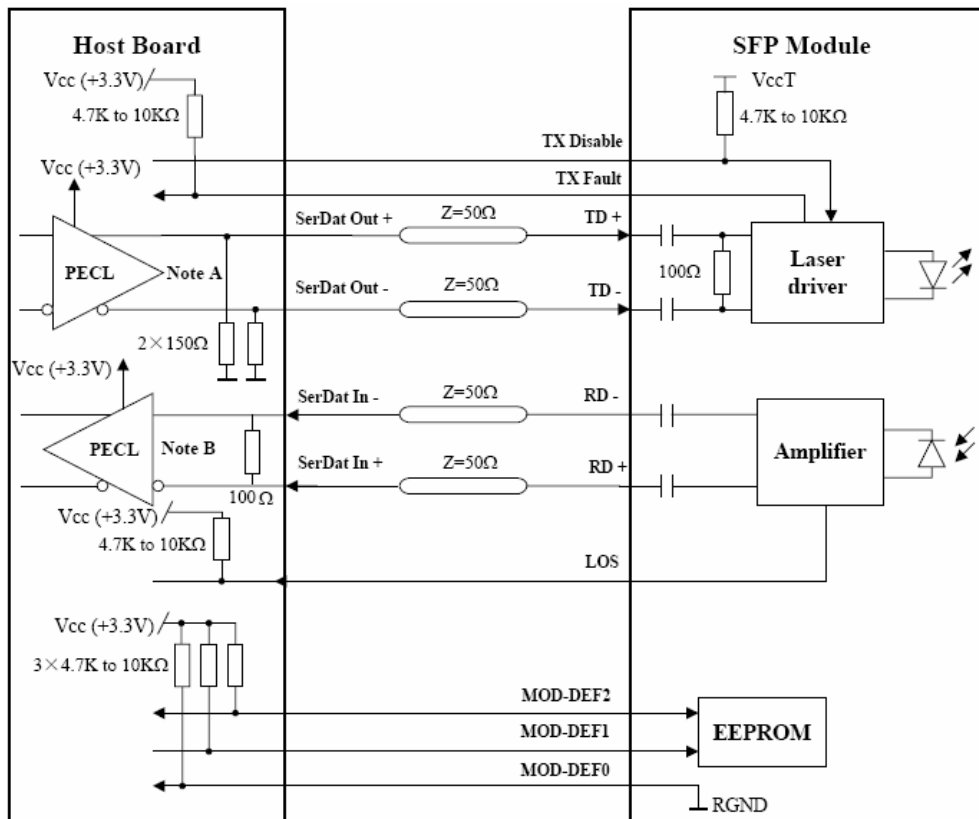

**Recommended Front Panel Layout Opening for LC**

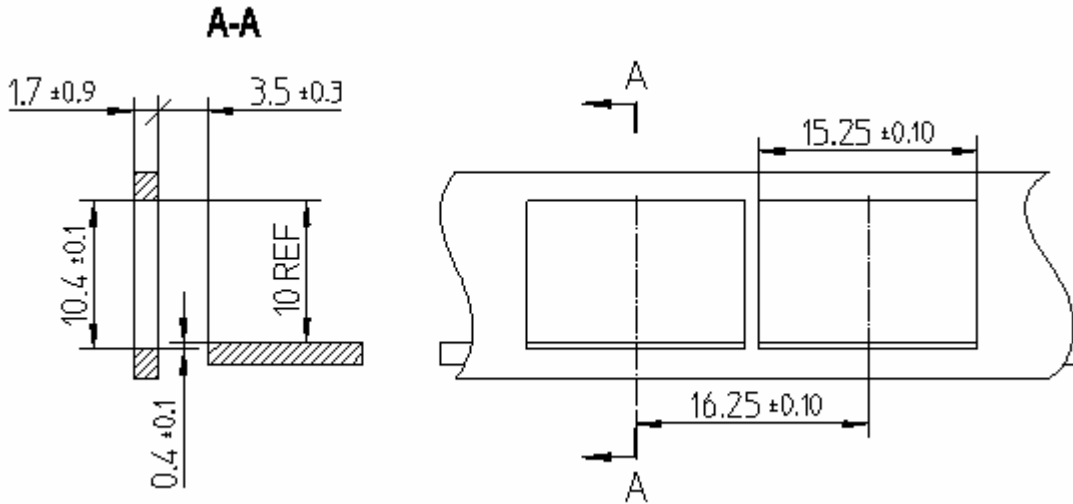

**Outline Specification**

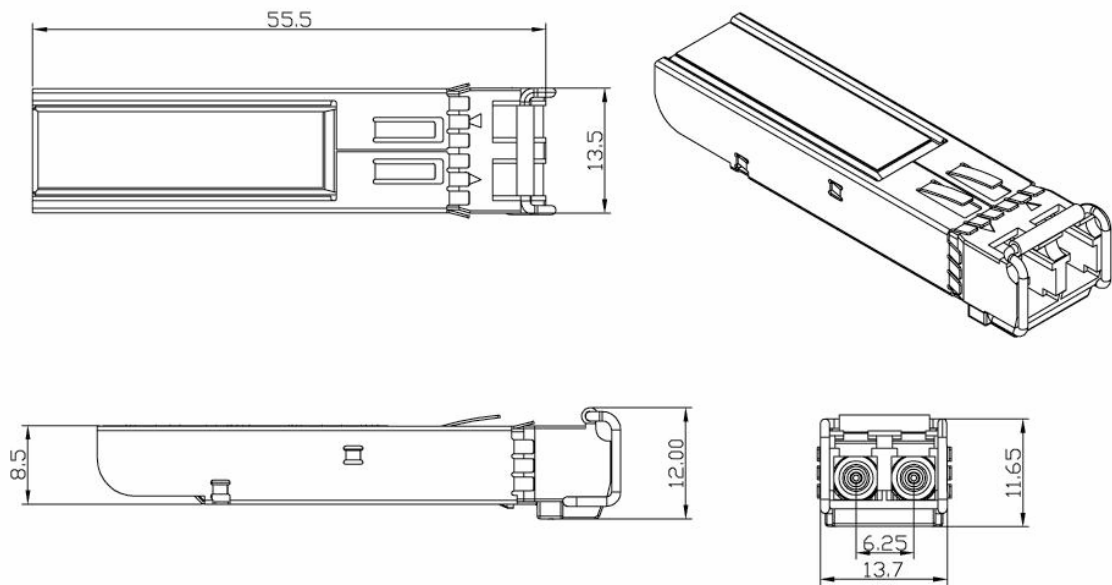



## 1250Mbps 1550nm SM SFP Transceiver 110km HOLS-PG15E-LN-CD/PG15E-LD-CD

---

### Ordering Information

Part Number	Wavelength	Monitor	LD Type	Temperature
HOLS- PG15E-LN-CD	1550nm	No DDM	DFB	-0°C~70°C
HOLS- PG15E-LD-CD	1550nm	DDM	DFB	-0°C~70°C