

Features:

- Compliant with SFP MSA standard
- 3.3V DC power supply
- DDM function implemented
- Uncooled 1550nm DFB, 622Mbps, 80km
- Built-in digital diagnostic function
- Difference LVPECL inputs and outputs
- Duplex LC connector
- Compliant with SFF-8472
- Hot Pluggable
- RoHS compliant
- Operating Temperature 0~70°C

Application:

- SDH/STM-4,SONET/OC-12
- Data storage networks
- Other optical links
- Optical access network



Description

Honlus 622Mbps single-mode SFP is a high performance and cost effective transceiver. It is designed to meet fast Ethernet application. The transceiver consists of two sections: the transmitter section consists of a high reliability 1550nm DFB laser diode (LD) with monitor photo detector (PD) in eye safety; the receiver section consists of a high-speed InGaAs PIN photodiode (PD) and trans-impedance preamplifier. The SFP is compatible with the Small Form Factor Pluggable Multi-Sourcing Agreement (MSA). Digital diagnostics functions are available via the 2-wire serial bus specified in the SFP MSA.

Ordering Information

Part Number	Wavelength	Monitor	LD Type	Temperature
HOLS-P6158-LN-CD	1550nm	No DDM	DFB	0°C~70°C
HOLS-P6158-LD-CD	1550nm	DDM	DFB	0°C~70°C

Absolute Maximum Ratings

Parameter	Symbol	Min	Max	Unit
Storage Temperature	T_S	-40	85	$^{\circ}\text{C}$
Storage Relative Humidity	RH_S	5	95	%
Power Supply	VCC	-0.5	4	V
Lead Solder Temperature	T_{SLD}	-	260	$^{\circ}\text{C}$
Lead Solder Duration	t_{SLD}	-	10	s

Operating Temperature Conditions

Parameter	Symbol	Min	Max	Unit
Operating Temperature	T_o	0	70	$^{\circ}\text{C}$
Power Supply	VCC	3.15	3.45	V
Operating Current	$I_{\text{TX+RX}}$	-	300	mA

Performance Specification

Transmitter Electro-Optical Characteristics						
Parameter	Symbol	min	Typ	Max	Unit	Note
Supply Voltage	VCC	3.15	3.3	3.45	V	
Differential Input Voltage	V_{IN}	500	-	2400	mV	AC coupled
Data Rate	Rate	-	622	-	Mbps	
Optical Output Power	P_o	-3	-	2	dBm	9/125 μm fiber
Extinction Ratio	ER	8.2	-	-	dB	
Central Wavelength	λ /DFB	1500	1550	1580	nm	
Output Spectrum Width	$\Delta\lambda$ /DFB	-	-	1	nm	RMS
Optical Rise Time	T_r	-	-	150	ps	20%~80%

Optical Fall Time	T_f	-	-	150	ps	20%~80%
Eye Diagram	Compliant IEEE802.3z					

Receiver Electro-Optical Characteristics						
Parameter	Symbol	min	Typ	Max	Unit	Note
Supply Voltage	VCC	3.10	3.3	3.5	V	
Differential Output Voltage	V_{OUT}	400	-	2000	mV	1
Data Rate	Rate	-	622	-	Mbps	
Receiver Sensitivity	S	-	-	-28	dBm	2
Optical Input Overload	P_{OL}	-8	-	-	dBm	
Operating Central Wavelength	λ	1260	-	1580	nm	
Loss of Signal-Asserted	$P_{RX_LOS\ A}$	-40	-	-	dBm	
Loss of Signal-Deasserted	$P_{RX_LOS\ D}$	-	-	-28	dBm	
Los of Signal Hysteresis	P_H	0.5	3	5	dB	

Note 1: Internally AC coupled.

Note 2: Average received power where the BER = 10^{-10} , measured with a $2^{23}-1$ NRZ test pattern..

Block Diagram

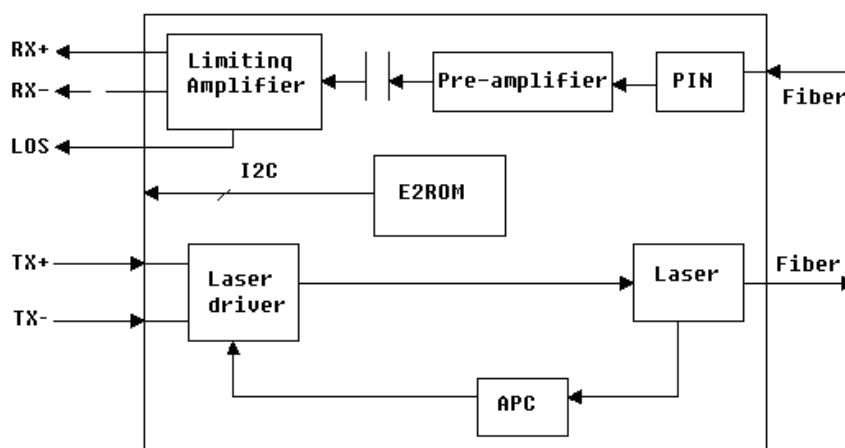

Figure1. Block Diagram

PECL Logic Level

Logic State	Unit	Min	Typ	Max
Low	V	VCC-1.84	-	VCC-1.60
High	V	VCC-1.10	-	VCC-0.90

TTL Logic Level

Logic State	Unit	Min	Typ	Max
Low	V	0	-	0.8
High	V	2.4	-	VCC

Transceiver Pin Locations

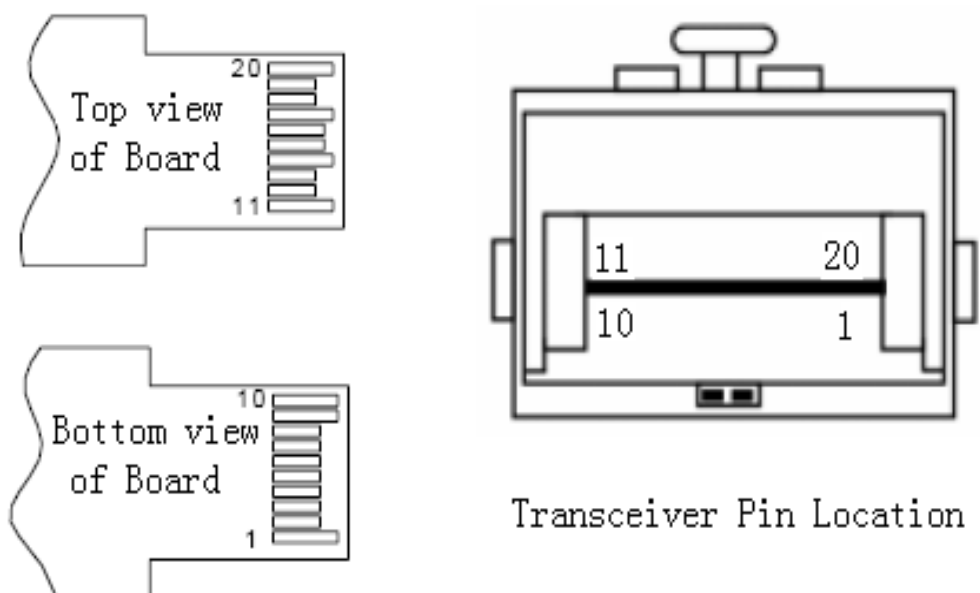

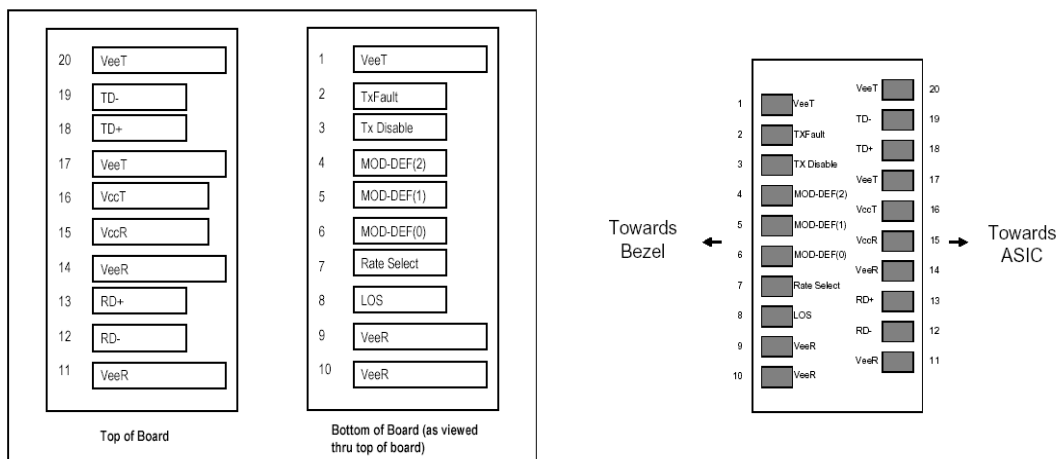

SFP Transceiver Electric Pad Layout

Diagram of Host Board Connector
Block Pin Number and Names

Figure2. Transceiver Pin Locations

Pin Descriptions

Pin	Name	Description	Plug Sequence	Note
1	VeeT	Transmitter Ground	1	
2	TX Fault	Transmitter Fault Indication	3	1
3	TX Disable	Transmitter Disable	3	4
4	MOD_DEF2	Module Definition 2	3	3
5	MOD_DEF1	Module Definition 1	3	3
6	MOD_DEF0	Module Definition 0	3	3
7	Rate Select	Select between Full or Reduced Receiver Bandwidth	3	4
8	LOS	Loss of Signal	3	5
9	VeeR	Receiver Ground	1	6
10	VeeR	Receiver Ground	1	6
11	VeeR	Receiver Ground	1	6
12	RD-	Inverse Received Data Out	3	7

13	RD+	Received Data Out	3	7
14	VeeR	Receiver Ground	1	6
15	VccR	Receiver Power	2	8
16	VccT	Transmitter Power	2	8
17	VeeT	Transmitter Ground	1	6
18	TD+	Transmit Data In	3	9
19	TD-	Inverse Transmit Data In	3	9
20	VeeT	Transmitter Ground	1	6

Note:

1. TX Fault is an open collector/drain output, which should be pulled up with a 4.7k ~ 10kΩ resistor on the host board to a voltage between 2.0V and Vcc+0.3V. Logic 1 indicates a laser fault of some kind; Logic 0 indicates normal operation. In the low state, the output will be pulled to less than 0.8V.
2. TX Disable is an input that is used to shut down the transmitter optical output. It is pulled up within the module with a 4.7k ~ 10 kΩ resistor. Its states are:
 - Low (0~0.8V): Transmitter on
 - (>0.8V, <2.0V): Undefined
 - High (2.0~3.465V): Transmitter Disabled
 - Open: Transmitter Disable
3. MOD-DEF 0, 1, 2 are the module definition pins. They should be pulled up with a 4.7k ~ 10 kΩ resistor on the host board. The pull-up voltage shall be VccT or VccR.
 - MOD-DEF 0 is grounded by the module to indicate that the module is present
 - MOD-DEF 1 is the clock line of two wire serial interface for serial ID
 - MOD-DEF 2 is the data line of two wire serial interface for serial ID
4. Rate select is not connected
5. LOS (Loss of Signal) is an open collector/drain output, which should be pulled up with a 4.7k ~ 10 kΩ resistor on the host board to a voltage between 2.0V and Vcc+0.3V. Logic 0 indicates normal operation; logic 1 indicates loss of signal. In the low state, the output will be pulled to less than 0.8V.
6. VeeR and VeeT may be internally connected within the SFP module.
7. These are the differential receiver outputs. They are AC-coupled 100Ω differential lines which should be terminated with 100Ω (differential) at the user SERDES. The AC coupling is done inside the module and is thus not required on the host board. The voltage swing on these lines will be between 370 and

- 2000mV differential (185-1000mV single ended) when properly terminated.
- VccR and VccT are the receiver and transmitter power supplies. They are defined as 3.3V +/-5% at the SFP connector pin. Maximum supply current is 300mA. Recommended host board power supply filtering is shown below. Inductors with DC resistance of less than 1Ω should be used in order to maintain the required voltage at the SFP input pin with 3.3V supply voltage. When the recommended supply filtering network is used, hot plugging of the SFP transceiver module will result in an inrush current of no more than 30mA greater than the steady state value. VccR and VccT may be internally connected within the SFP transceiver module.
 - These are the differential transmitter inputs. They are AC-coupled, differential lines with 100Ω differential termination inside the module. The AC coupling is done inside the module and is thus not required on the host board. The inputs will accept differential swing of 500mV – 2400mV (250mV-1200mV single-ended), though it is recommended that values between 500 and 1200mV differential (250mV-600mV single ended) be used for best EMI performance.

Power Supply

The Transceiver includes internal circuit components to filter power supply noise. Under some conditions of EMI and power supply noise, external power supply filtering may be necessary. If receiver sensitivity is found to be degraded by power supply noise, the filter network illustrated in the following figure may be used to improve performance. The values of the filter components are general recommendations and may be changed to suit a particular system environment. Shielded inductors are recommended.

Recommended Host Board Supply Filtering Circuit

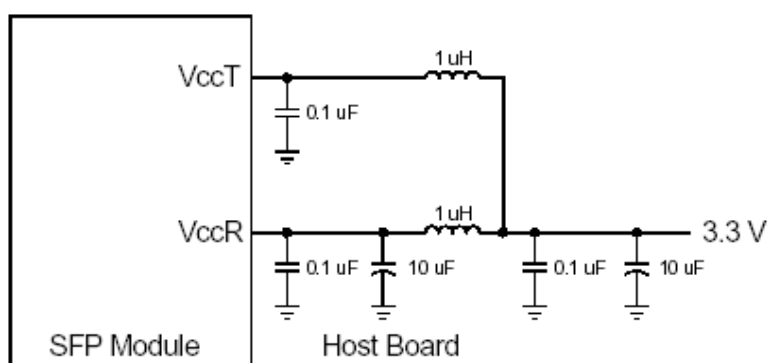

Figure3. Host Board Supply Filtering Circuit

Recommended Application Circuits

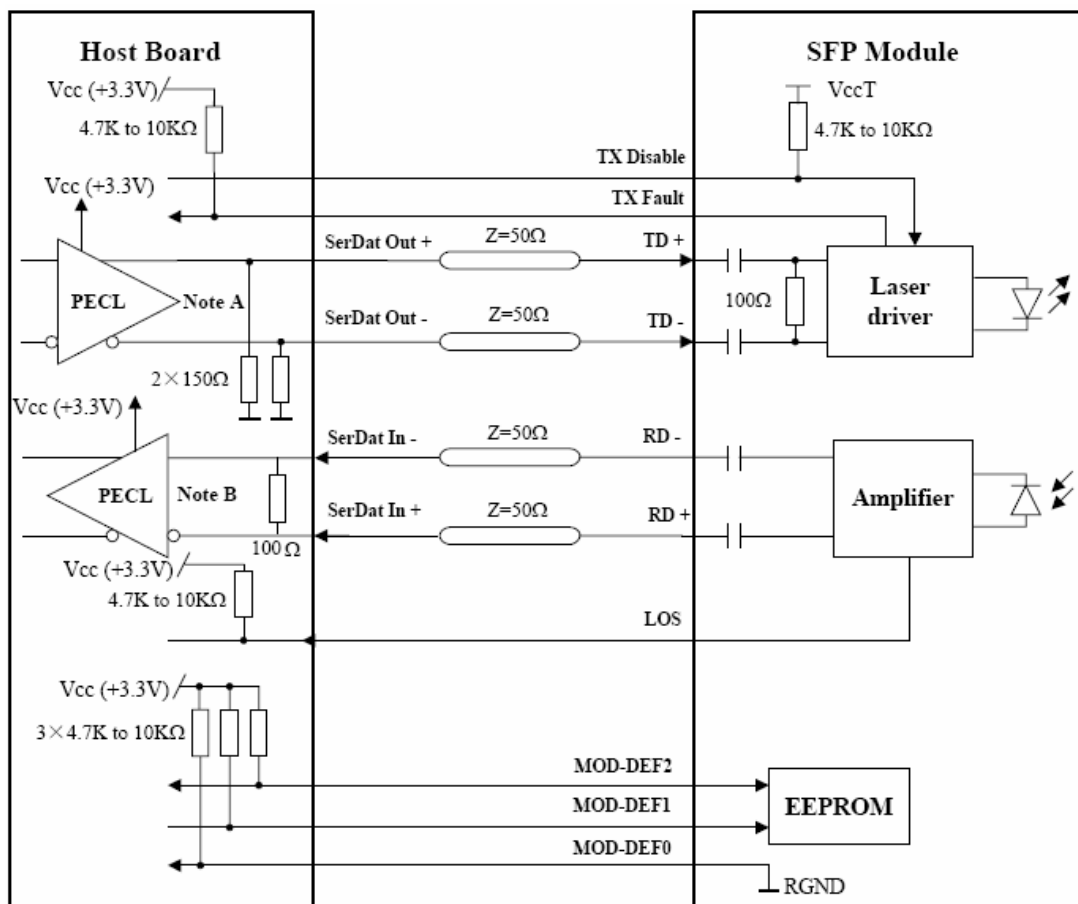

Figure4. Application Circuits

I²C Specifications

The SFP Module defines a 256-byte memory map in EEPROM describing the modules capabilities, standard interfaces, manufacturer, and other information that is accessible over a two wire serial interface at the 8-bit address 10100000 (A0h). The memory contents refer to Tables 6. The digital diagnostic monitoring interface defines another 256-byte memory map in EEPROM that use the 8 bit address 1010001X (A2h) (see figure 1 for details).

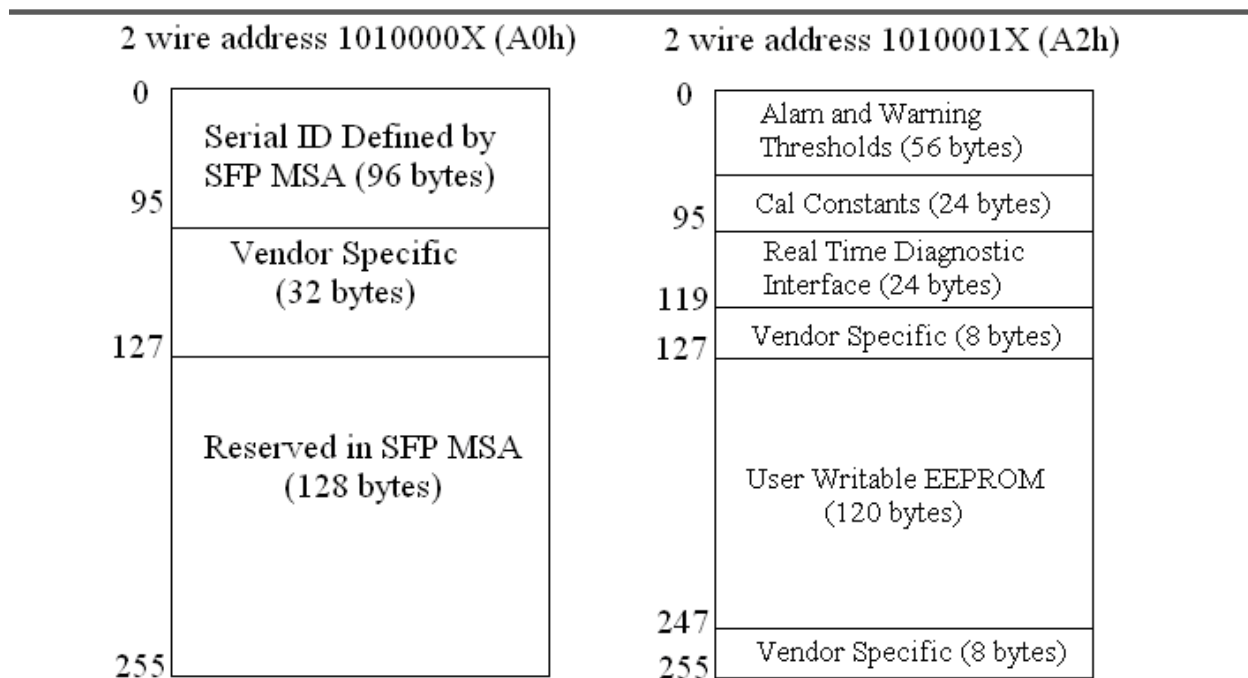

Figure5. EEPROM Serial ID Memory Contents

I²C Read/Write Memory Contents (A0h) Information

Address	Size (Bytes)	Name of Field	Contents (Hex)	Description
0	1	Identifier	03	SFP
1	1	Ext. Identifier	04	MOD4
2	1	Connector	07	LC
3-10	8	Transceiver	xxx	Transceiver Codes
11	1	Encoding	03	NRZ
12	1	BR, nominal	0C	622Mbps
13	1	Reserved	00	
14	1	Length (9um)-km	xx	Transmit distance
15	1	Length (9um)	xx	
16	1	Length (50um)	00	



622Mbps 1550nm SMF SFP Transceiver 80km HOLS-P6158-LD-CD

17	1	Length (62.5um)	00	
18	1	Length (copper)	00	
19	1	Reserved	00	
20-35	16	Vendor name	xxx	Company Name (ASC II) "Honlus"
36	1	Reserved	00	
37-39	3	Vendor OUI	00 00 00	
40-55	16	Vendor PN		Transceiver product number (ASC II)
56-59	4	Vendor rev		ASC II (31 30 20 20 means 1.0 revision)
60-61	2	Wavelength		Transceiver wavelength
62	1	Reserved	00	
63	1	CC BASE	Check Sum (variable)	Check code for base ID fields
64-65	2	Options	00 1A	TX_DISABLE, TX_FAULT and Loss of Signal implemented
66	1	BR, max		Vendor Assigned Part Number
67	1	BR, min		
68-83	16	Vendor SN	xxx	Serial Number (ASC II)
84-91	8	Vendor date code	xxx	Year (2 bytes), Month (2 bytes), Day (2 bytes)
92	1	Diagnostic type	58	Diagnostics (External Calibrated)
93	1	Enhanced option	B0	Diagnostics (Optional alarm/warning flags, Soft TX_FAULT and Soft TX_LOS monitoring)
94	1	SFF-8472	02	Diagnostics (SFF-8472 Rev 9.4)
95	1	CC EXT	XX	Check sum of bytes 64 -94 for extended ID fields
96-255	160	Vendor specific		

I²C Read/Write Memory Contents (A2h) Monitoring Interface

Address	Size (Bytes)	Name of Field	Description
00-01	2	Temperature High Alarm	Temperature set to 100°C

02-03	2	Temperature Low Alarm	Temperature set to -45°C
04-05	2	Temperature High Warning	Temperature set to 90°C
06-07	2	Temperature Low Warning	Temperature set to -40°C
08-09	2	Vcc High Alarm	Set to 3.6V
10-11	2	Vcc Low Alarm	Set to 3.0V
12-13	2	Vcc High Warning	Set to 3.5V
14-15	2	Vcc Low Warning	Set to 3.1V
16-17	2	Bias High Alarm	2 * IBias(25°C)+30
18-19	2	Bias Low Alarm	25%*IBias(25°C)
20-21	2	Bias High Warning	2*IBias(25°C)+20
22-23	2	Bias Low Warning	50%*IBias(25°C)
24-25	2	TX Power High Alarm	Manufacture measurement plus 2dB
26-27	2	TX Power Low Alarm	Manufacture measurement minus 2dB
28-29	2	TX Power High Warning	Manufacture measurement plus 1.5dB
30-31	2	TX Power Low Warning	Manufacture measurement minus 1.5dB
32-33	2	RX Power High Alarm	Maximum input optical power
34-35	2	RX Power Low Alarm	Minimum input optical power
36-37	2	RX Power High Warning	Maximum input optical power minus3dB
38-39	2	RX Power Low Warning	Minimum input optical power plus 3dB
40-55	16	Reserved	
Calibration Constants			
56-59	4	RX Power Calibration Data 4	Single precision floating-point number
60-63	4	RX Power Calibration Data 3	
64-67	4	RX Power Calibration Data 2	
68-71	4	RX Power Calibration Data 1	
72-75	4	RX Power Calibration Data 0	
76-77	2	Bias Calibration Data 1	01 00 Fixed
78-79	2	Bias Calibration Data 0	00 00 Fixed
80-81	2	TX Power Calibration Data 1	01 00 Fixed
82-83	2	TX Power Calibration Data 0	00 00 Fixed
84-85	2	Temperature Calibration Data 1	01 00 Fixed
86-87	2	Temperature Calibration Data 0	00 00 Fixed
88-89	2	Vcc Calibration Data 1	01 00 Fixed
90-91	2	Vcc Calibration Data 0	00 00 Fixed
92-94	3	Reserved	
95	1	Check Sum	Checksum of bytes 0-94
Real Time Diagnostic Monitor Interface			
96	1	Measured Temperature MSB	Internally measured transceiver temperature.
97	1	Measured Temperature LSB	Comply with external calibration of SFF-8472

98	1	Measured Vcc MSB	Internally measured transceiver supply voltage Vcc. Comply with external calibration of SFF-8472
99	1	Measured Vcc LSB	
100	1	Measured LD Bias MSB	Measured transceiver LD bias current. Comply with external calibration of SFF-8472
101	1	Measured LD Bias LSB	
102	1	Measured TX Power MSB	Measured transceiver TX power. Comply with external calibration of SFF-8472
103	1	Measured TX Power LSB	
104	1	Measured RX Power MSB	Measured transceiver RX power. Comply with external calibration of SFF-8472
105	1	Measured RX Power LSB	
106-109	4	Reserved	
110	1	Logic Status	
111	1	AD Conversion	
112-119	8	Alarm and Warning Flags	
Vendor Specific			
120-127	8	Vendor Specific	Don't Access
128-247	120	User writable EEPROM	
248-255	8	Vendor Specific	Don't Access

Recommended Front Panel Layout Opening for LC

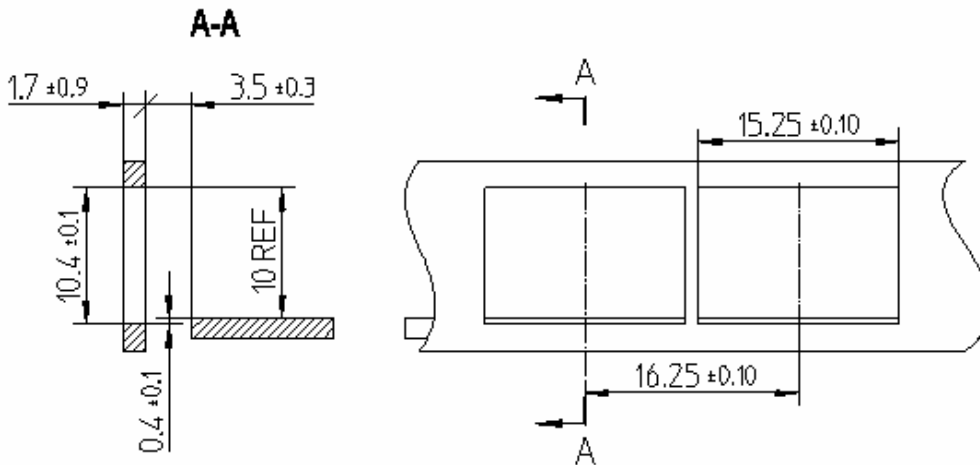

Outline Specification

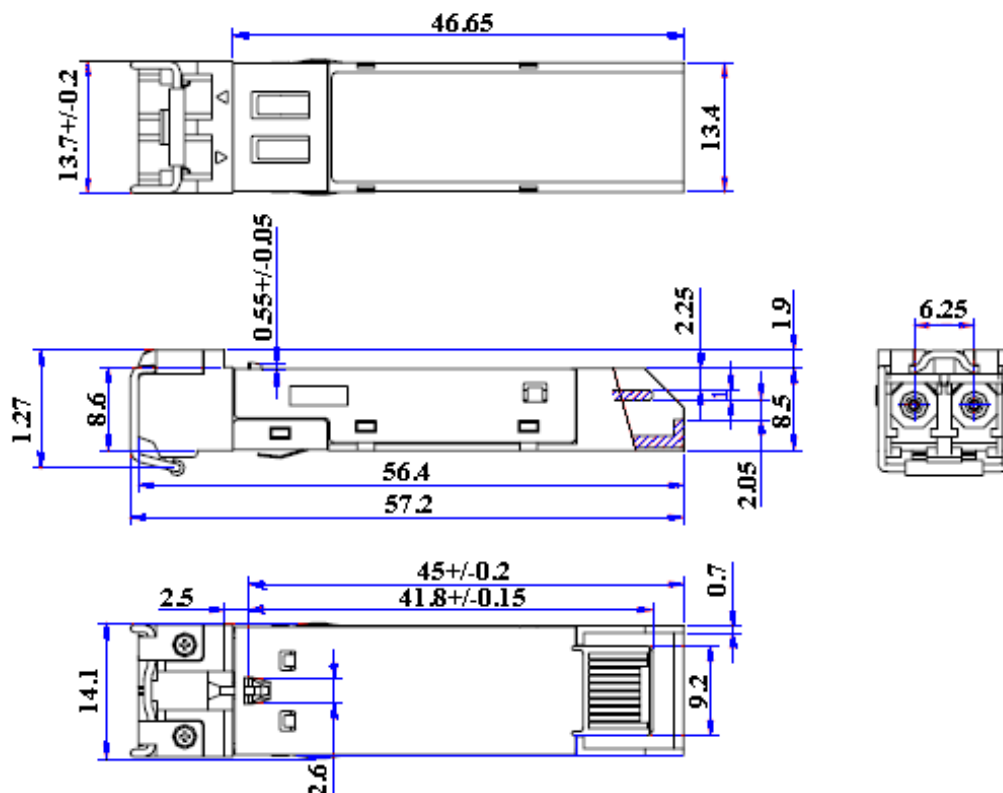

Safety Information

All versions of this laser are Class 1 laser products per IEC* 60825-1:2001. Users should observe safety precautions such as those recommended by ANSI** Z136.1-2000, ANSI Z36.2-1997 and IEC 60825-1:2001.

This product does not conform to 21 CFR 1040.10 and 1040.11. Consequently, this laser module is only intended for use as a component by manufacturers of electronic products and equipment.

Wavelength = 1.31 μ m

Maximum Power = 5 mW

Single-mode fiber pigtail

Fiber Numerical Aperture = 0.14

Labeling is not affixed to the laser module due to size constraints; rather, labeling is placed on the outside of the shipping box.

This product is not shipped with a power supply.

Caution: use of controls or adjustments or performance of procedures other than those specified herein may result in hazardous radiation exposure.

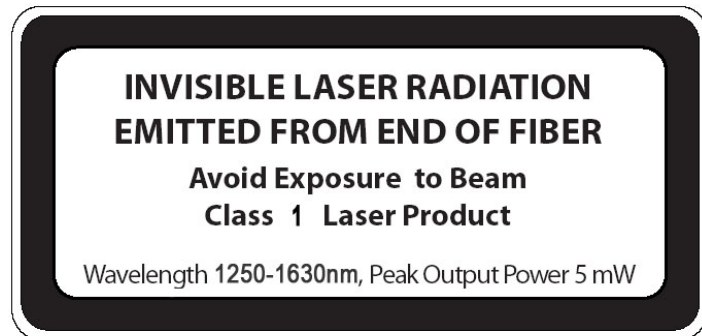

classified in accordance with IEC 60825-1:2001-08

*IEC is a registered trademark of the International Electrotechnical Commission

**ANSI is a registered trademark of the American National Standards Institute