

Product Features

QSFP+ AOC end:

- Compliant to the 40GBASE-SR4 and XLPI Specification per IEEE 802.3ba-2010 and supporting 40G-IB-QDR / 20G-IB-DDR / 10G-IB-SDR applications
- Compliant to the industry standard SFF-8436 QSFP+ Specification
- Power Level 1: Max Power < 1.5 W
- Operate at 10.3125 Gbps per channel with 64b/66b encoded data for 40GbE application and at 10 Gbps with 8b/10b compatible encoded data for 40G-IB-QDR application

Each 4× SFP+ end:

- Compliant to the electrical specifications per SFF-8431 Specifications for Enhanced Small Form Factor Pluggable Module
- Mechanical specifications per SFF Committee SFF-8432 Improved Pluggable Form factor "IPF"
- Maximum power dissipation 0.35W per end.

Active Optical Cable Assembly:

- 0 to 70 C degree case temperature operating range
- Proven High Reliability 850 nm technology: Honlu VCSEL transmitter and Honlus PIN receiver
- Hot pluggable for ease of servicing and installation
- Two Wire Serial interface
- Utilizes optical fiber for high density and thin, lightweight cable management

Applications

- 40GbE and 10GbE break-out applications for Datacom switch and router connections

- 40G to 4×10G density applications for Datacom and Proprietary protocol applications
- Datacenter

Description

The Honlus Technologies RA-T40NXXC-00 is a Four-Channel, Pluggable, Parallel, Fiber-Optic QSFP+ Active Optical Cable (AOC) to 4× SFP+ Active Optical Cable break-out solution. This Breakout cable is intended for 40G to 4× 10G applications.

This AOC is a high performance cable for short-range multi-lane data communication and interconnect applications. It integrates four data lanes in each direction with 40 Gbps aggregate bandwidth. Each lane can operate at 10.3125 Gbps. These cables also support 4 x 10G InfiniBand QDR applications and are backwards compatible to the 4 × 5G IB DDR and 4 × 2.5G IB single IB SDR applications.

This product is leveraged from Honlus Technologies QSFP+ to QSFP+ Active Optical Cable product and SFP+ Active Optical Cable product. Where applicable, consult these respective datasheets

This AOC incorporates Honlus Technologies' proven integrated circuit and VCSEL technology to provide reliable long life, high performance, and consistent service.

Absolute Maximum Ratings

The operation in excess of any absolute maximum ratings might cause permanent damage to this module.

Parameter	Symbol	Min	Max	Unit	Note
Storage Temperature	TST	-40	85	degC	
Relative Humidity(non-condensing)	RH	0	85	%	
Operating Case Temperature	TOPC	0	70	degC	
Supply Voltage	VCC	-0.3	3.6	V	
Input Voltage	Vin	-0.3	Vcc+0.3	V	

Recommended Operating Conditions and Supply Requirements

Parameter	Symbol	Min	Typical	Max	Unit
Operating Case Temperature	TOPC	0		70	degC
Power Supply Voltage	VCC	3.13	3.3	3.47	V
Data Rate	DR		10.3	11.3	Gbps
Data Speed Tolerance	Δ DR	-100		+100	ppm
Link Distance with OM3 fiber	D	0		100	m
Control* Input Voltage High	Vih	2		VCC+0.3	V
Control* Input Voltage Low	Vil	-0.3		0.8	V
I2C Serial Interface frequency	fs			400k	Hz
Power Supply Noise				50	mVpp
Receiver Differential Data Output Load				100	mVpp

Active Cable-End Electrical Characteristics

The following characteristics are defined over the Recommended Operating Conditions unless otherwise noted. Typical values are for $T_c = 40\text{ }^\circ\text{C}$, $V_{cc} = 3.3\text{ V}$

Parameter	Symbol	Min	Typical	Max	Unit
QSFP+ 40G Active Cable-End Power Consumption				1.5	W
QSFP+ 40G Active Cable-End Power Supply Current				300	mA
SFP+ 10G Active Cable-End Power Consumption				0.35	W
SFP+ 10G Active Cable-End Power Supply Current				100	mA

QSFP+ AOC-end Electrical Characteristics Electrical Specifications

Parameter	Symbol	Min	Typical	Max	Unit
Differential input impedance	Zin	90	100	110	ohm
Differential Output impedance	Zout	90	100	110	ohm
Differential input voltage amplitude	ΔV_{in}	300		1100	mVp-p
Differential output voltage amplitude	ΔV_{out}	400		800	mVp-p
Bit Error Rate	BR			E-12	
Input Logic Level High	V _{IH}	2.0		V _{CC}	V
Input Logic Level Low	V _{IL}	0		0.8	V
Output Logic Level High	V _{OH}	V _{CC} -0.5		V _{CC}	V
Output Logic Level Low	V _{OL}	0		0.4	V

QSFP+ AOC-end Pin Descriptions

PIN	Logic	Symbol	Name/Description	Note
1		GND	Ground	1
2	CML-I	Tx2n	Transmitter Inverted Data Input	
3	CML-I	Tx2p	Transmitter Non-Inverted Data output	
4		GND	Ground	1
5	CML-I	Tx4n	Transmitter Inverted Data Input	
6	CML-I	Tx4p	Transmitter Non-Inverted Data output	
7		GND	Ground	1
8	LVTLL-I	ModSelL	Module Select	

9	LVTTLL-I	ResetL	Module Reset	
10		VccRx	+ 3.3V Power Supply Receiver	2
11	LVCMMOS-I/O	SCL	2-Wire Serial Interface Clock	
12	LVCMMOS-I/O	SDA	2-Wire Serial Interface Data	
13		GND	Ground	
14	CML-O	Rx3p	Receiver Non-Inverted Data Output	
15	CML-O	Rx3n	Receiver Inverted Data Output	
16		GND	Ground	1
17	CML-O	Rx1p	Receiver Non-Inverted Data Output	
18	CML-O	Rx1n	Receiver Inverted Data Output	
19		GND	Ground	1
20		GND	Ground	1
21	CML-O	Rx2n	Receiver Inverted Data Output	
22	CML-O	Rx2p	Receiver Non-Inverted Data Output	
23		GND	Ground	1
24	CML-O	Rx4n	Receiver Inverted Data Output	1
25	CML-O	Rx4p	Receiver Non-Inverted Data Output	
26		GND	Ground	1
27	LVTTL-O	ModPrsL	Module Present	
28	LVTTL-O	IntL	Interrupt	
29		VccTx	+3.3 V Power Supply transmitter	2
30		Vcc1	+3.3 V Power Supply	2
31	LVTTL-I	LPMMode	Low Power Mode	
32		GND	Ground	1
33	CML-I	Tx3p	Transmitter Non-Inverted Data Input	
34	CML-I	Tx3n	Transmitter Inverted Data Output	
35		GND	Ground	1
36	CML-I	Tx1p	Transmitter Non-Inverted Data Input	
37	CML-I	Tx1n	Transmitter Inverted Data Output	
38		GND	Ground	1

Notes:

- 1) Module circuit ground is isolated from module chassis ground within the module. GND is the symbol for signal and supply (power) common for QSFP modules.
- 2) The connector pins are each rated for a maximum current of 500mA.

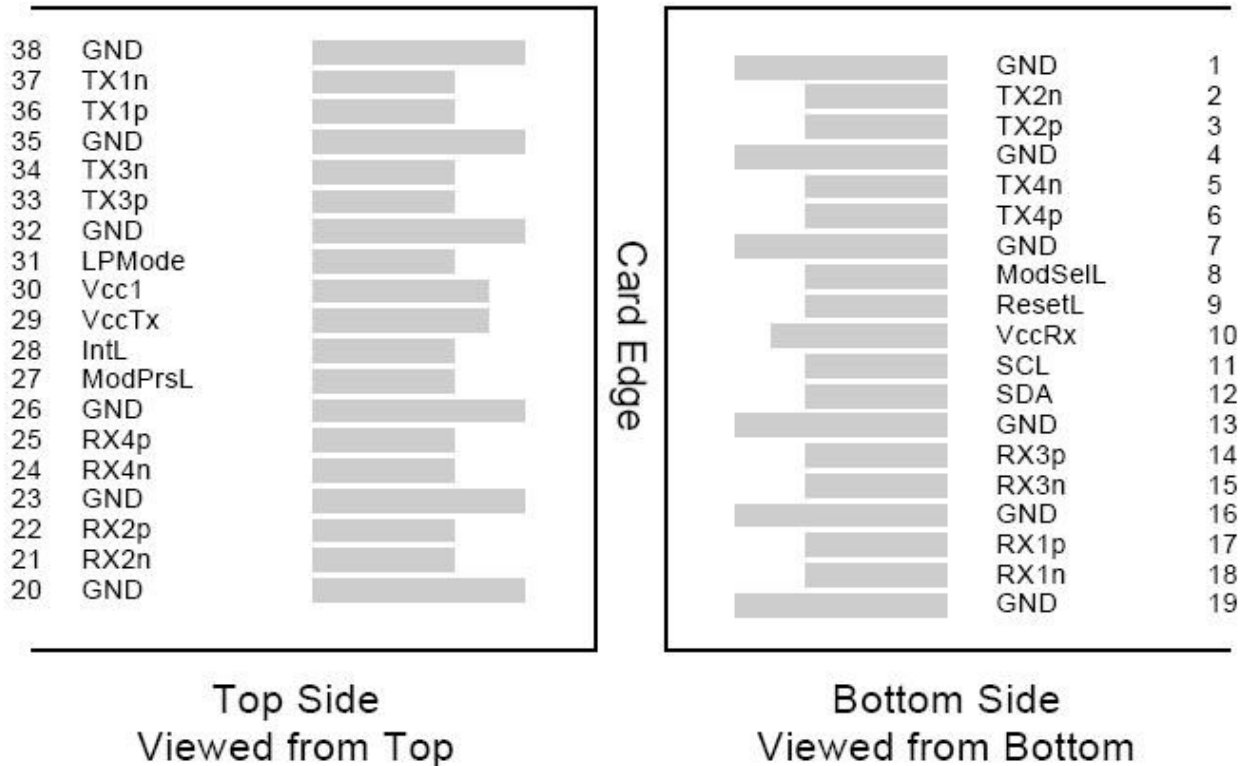

ModSelL Pin

The ModSelL is an input pin. When held low by the host, the module responds to 2-wire serial communication commands. The ModSelL allows the use of multiple QSFP modules on a single 2-wire interface bus. When the ModSelL is "High", the module will not respond to any 2-wire interface communication from the host. ModSelL has an internal pull-up in the module.

ResetL Pin

Reset. LPMode_Reset has an internal pull-up in the module. A low level on the ResetL pin for longer than the minimum pulse length (t_{Reset_init}) initiates a complete module reset, returning all user module settings to their default state. Module Reset

Assert Time (t_{init}) starts on the rising edge after the low level on the ResetL pin is released. During the execution of a reset (t_{init}) the host shall disregard all status bits until the module indicates a completion of the reset interrupt. The module indicates this by posting an IntL signal with the Data_Not_Ready bit negated. Note that on power up (including hot insertion) the module will post this completion of reset interrupt without requiring a reset.

LPMODE Pin

Honlus QSFP+ SR4 operate in the low power mode (less than 1.5 W power consumption) This pin active high will decrease power consumption to less than 1W.

ModPrsL Pin

ModPrsL is pulled up to Vcc on the host board and grounded in the module. The ModPrsL is asserted "Low" when the module is inserted and deasserted "High" when the module is physically absent from the host connector.

IntL Pin

IntL is an output pin. When "Low" , it indicates a possible module operational fault or a status critical to the host system. The host identifies the source of the interrupt by using the 2-wire serial interface. The IntL pin is an open collector output and must be pulled up to Vcc on the host board.

QSFP+ AOC-end Power Supply Filtering

The host board should use the power supply filtering shown in Figure1.

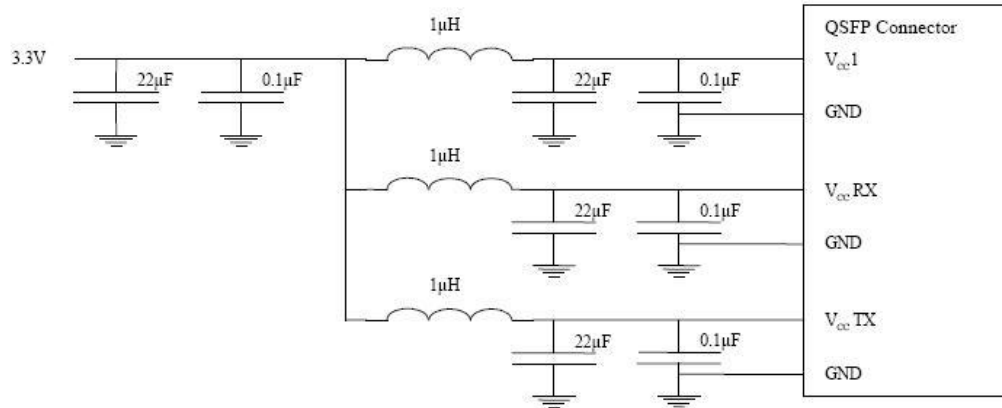

Figure1. Host Board Power Supply Filtering

QSFP+ AOC-end EEPROM Serial ID Memory Contents:

Compliant to the industry standard SFF-8436 QSFP+ Specification

SFP+ AOC-end Electrical Specifications

Parameter	Symbol	Min	Typical	Max	Unit
Differential input impedance	Zin	90	100	110	ohm
Differential Output impedance	Zout	90	100	110	ohm
Differential input voltage amplitude aAmplitude	ΔV_{in}	100		1800	mVp-p
Differential output voltage amplitude	ΔV_{out}	400		800	mVp-p
Bit Error Rate	BR			E-12	

Input Logic Level High	VIH	2.0		VCC	V
Input Logic Level Low	VIL	0		0.8	V

SFP+ AOC-end Pin Descriptions

PIN	Symbol	Name/Description	Note
1	VeeT	Transmitter Signal Ground	Note 1
2	TX_FAULT	Transmitter Fault (LVTTL-O) – Not used. Grounded inside the module	Note 2
3	TX_DISABLE	Transmitter Disable (LVTTL-I) – High or open disables the transmitter	Note 3
4	SDA	Two Wire Serial Interface Data Line (LVCMOS – I/O) (same as MOD-DEF2 in INF-8074)	Note 4
5	SCL	Two Wire Serial Interface Clock Line (LVCMOS – I/O) (same as MOD-DEF1 in INF-8074)	Note 4
6	MOD_ABS	Module Absent (Output), connected to VeeT or VeeR in the module	Note 5
7	RS0	Rate Select 0 - Not used, Presents high input impedance.	
8	RX_LOS	Receiver Loss of Signal (LVTTL-O)	Note 2
9	RS1	Rate Select 1 - Not used, Presents high input impedance.	
10	VeeR	Receiver Signal Ground	Note 1
11	VeeR	Receiver Signal Ground	Note 1
12	RD-	Receiver Data Out Inverted (CML-O)	
13	RD+	Receiver Data Out (CML-O)	

14	VeeR	Receiver Signal Ground	
15	VccR	Receiver Power + 3.3 V	
16	VccT	Transmitter Power + 3.3 V	
17	VeeT	Transmitter Signal Ground	Note 1
18	TD+	Transmitter Data In (CML-I)	
19	TD-	Transmitter Data In Inverted (CML-I)	
20	VeeT	Transmitter Signal Ground	Note 1

Notes:

1. Module circuit ground is isolated from module chassis ground within the module. GND is the symbol for signal and supply (power) common for SFP modules.
2. This is an open collector/drain output that on the host board requires a 4.7 kΩ to 10 kΩ pullup resistor to VccHost. See Figure 2.
3. This input is internally biased high with a 4.7 kΩ to 10 kΩ pullup resistor to VccT.
4. Two-Wire Serial interface clock and data lines require an external pullup resistor dependent on the capacitance load.
5. This is a ground return that on the host board requires a 4.7 kΩ to 10 kΩ pullup resistor to VccHost.

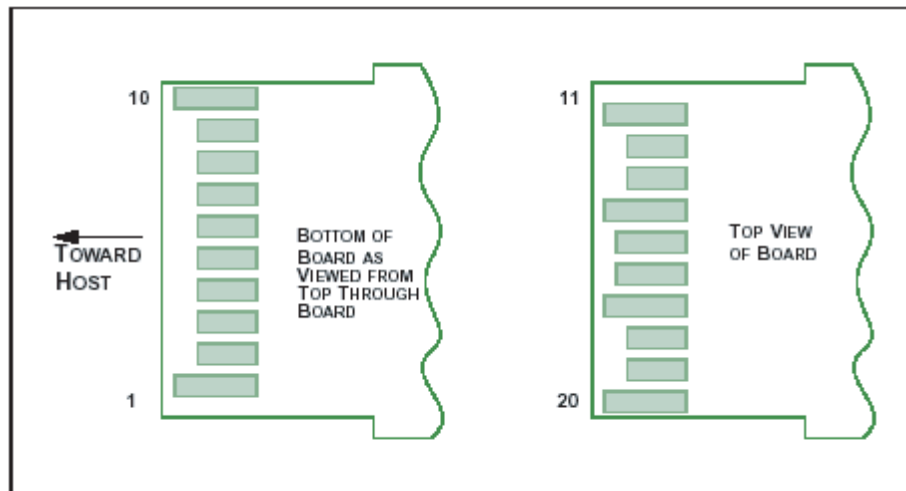

QSFP+ AOC-end Power Supply Filtering

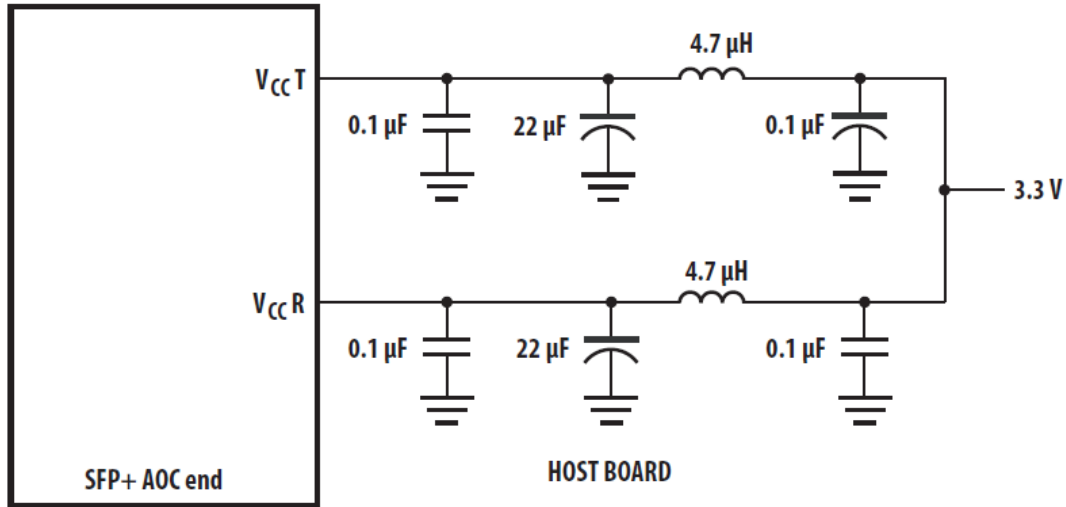

NOTE: INDUCTORS MUST HAVE LESS THAN 1Ω SERIES RESISTANCE TO LIMIT VOLTAGE DROP TO THE SFP MODULE.

Optical Fiber Specifications

Parameter	Specification
Tight buffer color	Blue
Tight buffer material	PVC
Fiber type	62.5/125 (OFS) Bandwith:160 MHz.km @ 850 nm
Jacket material	PVC
Cable diameter mm	3.0 ± 0.1

Cable weight Kg/km	7.0
Min. bending radius mm	30
Attenuation dB/km	≤ 3.5 at 850 nm ≤ 1.5 at 1300 nm
Short tension N	120
Operation temperature °C	-20~70

SFP+ AOC end Mechanical Specifications

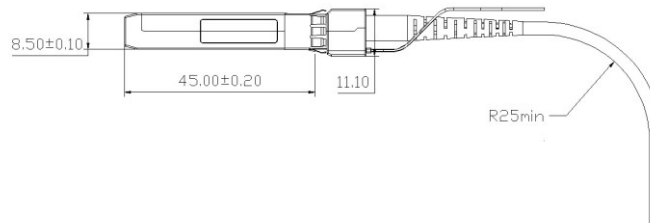
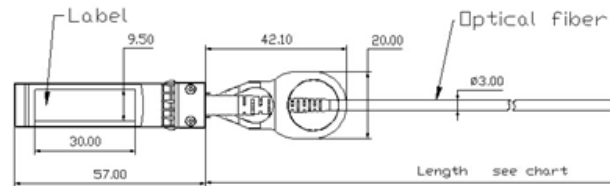

QSFP+ AOC end Mechanical Specifications

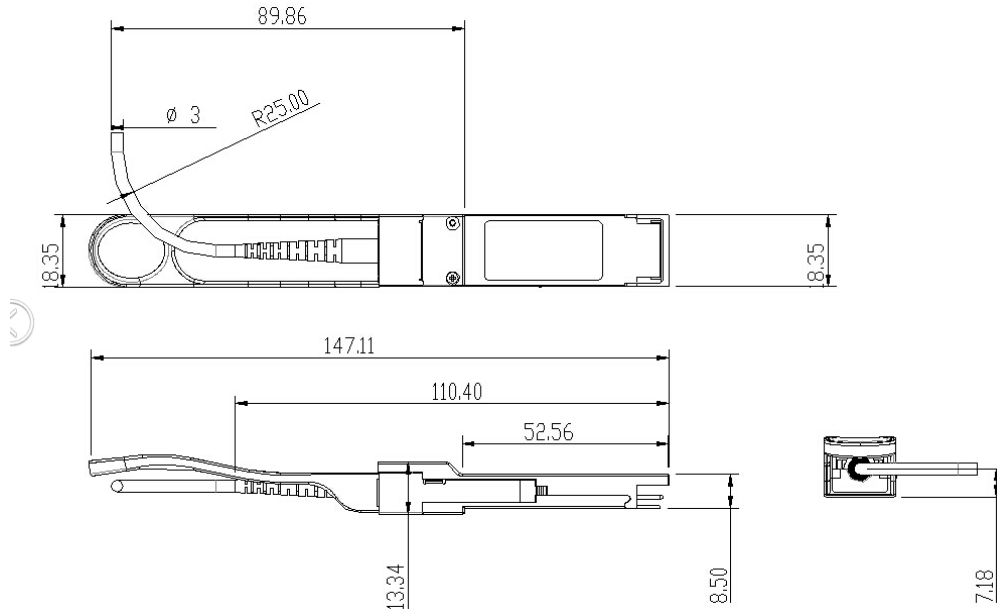

ESD

This transceiver is specified as ESD threshold 1KV for high speed data pins and 2KV for all others electrical input pins, tested per MIL-STD-883, Method 3015.4 /JESD22-A114-A (HBM). However, normal ESD precautions are still required during the handling of this module. This transceiver is shipped in ESD protective packaging. It should be removed from the packaging and handled only in an ESD protected environment.

Laser Safety

This is a Class 1 Laser Product according to IEC 60825-1:2007. This product complies with 21 CFR 1040.10 and 1040.11 except for deviations pursuant to Laser Notice No. 50, dated (June 24, 2007)



**40Gb/s QSFP+ to 4x 10Gb/s AOC, 850nm, 100m
HOLS-AQPP85Mxxx-PPD-CV**

Order Information

Part Number	Product Description
HOLS-AQPP85Mxxx-PPD-CV	40Gb/s QSFP+ – 4x10G SFP+ Active Optical Cable

Notes:

where "xxx" denotes cable length in meters. Examples are as follows:

xxx = 003 for 3m, xxx = 01 for 10m, xxx = 05 for 50m, xxx = 1 for 100m

Performance figures, data and any illustrative material provided in this data sheet are typical and must be specifically confirmed in writing by Honlus before they become applicable to any particular order or contract. In accordance with the Honlus policy of continuous improvement specifications may change without notice. The publication of information in this data sheet does not imply freedom from patent or other protective rights of Honlus or others. Further details are available from any Honlus sales representative.