

6.144G 10KM 1310nm SFP+ Optical Transceiver

Features

- Support Multi Rate up to 6.25 Gbps
- CPRI/OBSAI Compatible Optical Interface
- Hot Pluggable SFP+ footprint
- 1310nm DFB transmitter, PIN photo-detector
- Transmission distance up to 10km on 9/125 μ m SMF
- Digital Status monitoring Interface
- Duplex LC connector
- RoHS compliant and Lead Free
- Metal enclosure for lower EMI
- Single 3.3V power supply
- Power dissipation <1W
- Compliant with FC-PI-4 800-Mx-SN-I, SFF-8431 , SFF-8432 and SFF-8472
- Operating case temperature:
Standard: 0 to +70°C
Industrial: -40 to +85°C



Applications

- Radio Base Station
- CPRI or OBSAI rates:
614.4Mb/s,1228.8Mb/s,1536Mb/s,2457.6Mb/s,3072Mb/s,4915.2Mb/s,6144Mb/s
- LTE optical repeater application

Description

Honlus HOLS-PP131066-LD-xD is a high performance, cost effective modules for serial optical data communications such as CPRI and OBSAI. which is supporting Multi Rate Up to 6.25Gbps, and transmission distance up to 10km on SM fiber.

The transceiver consists of two sections: The transmitter section incorporates a 1310nm DFB driver and re-timer. The receiver section consists of a PIN photodiode integrated with a transimpedance preamplifier (TIA). The module is hot pluggable into the 20-pin connector. The high-speed electrical interface is base on low voltage logic, with nominal 100 Ohms differential impedance and AC coupled in the module.

Module Block Diagram

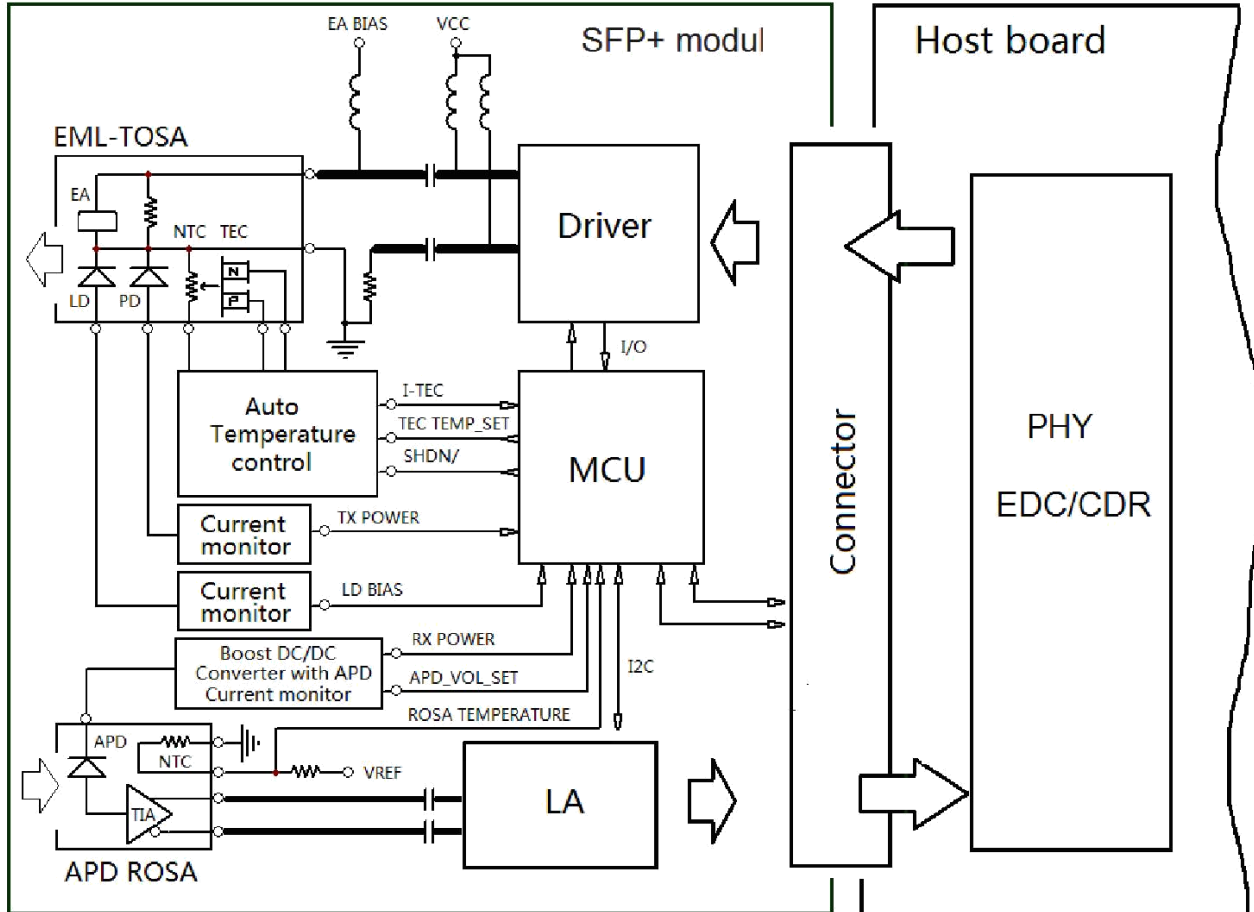

Figure1. Module Block Diagram

Absolute Maximum Ratings

These values represent the damage threshold of the module. Stress in excess of any of the individual Absolute Maximum Ratings can cause immediate catastrophic damage to the module even if all other parameters are within Recommended Operating Conditions.

Parameters	Symbol	Min.	Max.	Unit
Power Supply Voltage	Vcc	0	+3.6	V
Storage Temperature	Tc	-40	+85	C
Relative Humidity	RH	5	95	%

Operating Conditions

Recommended Operating Environment specifies parameters for which the electrical and optical characteristics hold unless otherwise noted.

Parameter	Symbol	Min.	Typical	Max	Unit
Power Supply Voltage	V _{cc}	3.135	3.300	3.465	V
	I _{cc}			300	mA
Operating Case Temperature	T _c	0	25	70	C
	T _c	-40	25	85	C
Power Dissipation	PD			1	W
Data Rate	CPRI/OBSAI			6.25	Gbps
Transmission Distance				10	km

LOW Speed Characteristics

Parameter	Symbol	Min.	Typical	Max	Unit
Power Consumption				1	W
TX_Fault,RX_LOS	VOL	0		0.4	V
	VOH	Host_Vcc-0.5		Host_Vcc+0.3	V
TX_DIS	VIL	-0.3		0.8	V
	VIH	2.0		VCCT+0.3	V
RS0,RS1	VIL	-0.3		0.8	V
	VIH	2.0		VCCT+0.3	V

Optical characteristics

Parameter	Symbol	Min.	Typical	Max	Unit	Notes	
Transmitter							
Center Wavelength	λ _t	1284	1310	1345	nm	Note1	
RMS spectral width	P _m	-	-	1	nm		
Average Optical Power	P _{avg}	-6	-	-0.5	dBm	Note1	
Laser Off Power	P _{off}			-30	dBm		
Extinction Ratio	ER	3.5	-	-	dB		
Relative Intensity Noise	R _{in}			-128	dB/Hz		
Optical Eye Mask	Compliant with IEEE 802.3ae						Note2
Single Ended Output Voltage Tolerance		-0.3		4	V		
Common Mode Voltage Tolerance		15			mV		
Tx Input Diff Voltage	V _I	180		700	mV		

Data Dependent Input Jitter	DDJ			0.1	UI	
Data Input Total Jitter	TJ			0.28	UI	
		Receiver				
Center Wavelength	λ_r	1260		1360	nm	
Receiver Sensitivity	Psens			-15	dBm	
LOS Assert	LosA	-30			dBm	
LOS De-assert	LosD			-16	dBm	
Los Hysteresis	LosH	0.5			dBm	
Overload	Pin	0.5			dBm	
Stressed Eye Jitter		0.3			Ulp-p	
Receiver electrical 3dB upper cutoff frequency				12.3	GHz	
Vertical Eye Closure Penalty		2.2			dB	
Single Ended Output Voltage Tolerance		-0.3		4	V	
Rx Output Diff Voltage	Vo	450		850	mV	
Rx Output Rise and Fall Time	Tr/Tf	30			ps	
Total Jitter	TJ			0.7	UI	
Deterministic Jitter	DJ			0.42	UI	
Stressed Receiver Sensitivity in OMA				-10.3	dBm	
Receiver Reflectance		-	-	-12	dB	Note3

Notes:

1. Average optical power shall be measured using the methods specified in TIA/EIA-455-95.
2. Vertical eye closure penalty and stressed eye jitter are the test conditions for measuring stressed receiver sensitivity. They are not the required characteristic of the receiver.

Transmitter Specifications – Electrical

Parameter	Symbol	Min	Typical	Max	Unit
Data Rate	Mra	-	10.3	11.3	Gbps
Input differential impedance	Rim	-	100	-	Ω
Differential data Input	VtxDIFF	120	-	850	mV
Transmit Disable Voltage	VD	2.0	-	Vcc3+0.3	V
Transmit Enable Voltage	Ven	0	-	+0.8	V
Transmit Disable Assert Time	Vn	-	-	100	us

Receiver Specifications – Electrical

Parameter	Symbol	Min	Typical	Max	Unit
Data Rate	Mra	-	10.3	11.3	Gbps
Differential Output Swing	Vout P-P	350	-	850	mV
Rise/Fall Time	Tr / Tf	24	-	-	ps
Loss of Signal –Asserted	VOH	2	-	Vcc3+0.3-	V
Loss of Signal –Negated	VOL	0	-	+0.4	V

Digital Diagnostic Functions

The following digital diagnostic characteristics are defined over the Recommended Operating Environment unless otherwise specified. It is compliant to SFF8472 Rev9.2 with internal calibration mode. For external calibration mode please contact our sales staff.

Parameter	Symbol	Min.	Max	Unit	Notes
Accuracy					
Transceiver Temperature	DMI_Temp	-3	+3	degC	Over operating temp
TX Output optical power	DMI_TX	-3	+3	dB	
RX Input optical power	DMI_RX	-3	+3	dB	-3dBm to -12dBm range
Transceiver Supply voltage	DMI_VCC	-0.08	+0.08	V	Full operating range
Bias current monitor	DMI_Ibias	-10%	10%	mA	
Dynamic Range Accuracy					
Transceiver Temperature	DMI_Temp	-5	70	degC	
TX Output optical power	DMI_TX	-9	-1	dBm	
RX Input optical power	DMI_RX	-18	0	dBm	

Transceiver Supply voltage	DMI_VCC	3.0	3.6	V	
Bias current monitor	DMI_Ibias	0	16	mA	

Control and status I/O timing characteristics

Timing characteristics of control and status I/O are included in Table 8, which is also defined in SFF-8431.

Parameter	Symbol	Min.	Max.	Unit	Conditions
TX_Disable assert time	t_off		100	μs	rising edge of TX_Disable to fall of output signal below 10% of nominal
TX_Disable negate time	t_on		2	ms	Falling edge of Tx_Disable to rise of output signal above 90% of nominal. This only applies in normal operation, not during start up or fault recovery.
Time to initialize 2-wire interface	t_2w_start_up		300	ms	From power on or hot plug after the supply meeting Table 8 .
Time to initialize	t_start_up		300	ms	From power supplies meeting Table 8 or hot plug or Tx disable negated during power up, or Tx_Fault recovery, until non-cooled power level I part (or non-cooled power level II part already enabled at power level II for Tx_Fault recovery) is fully operational.
Time to initialize cooled module	t_start_up_cooled		90	s	From power supplies meeting Table 8 or hot plug, or Tx disable negated during power up or Tx_Fault recovery, until cooled power level I part (or cooled power level II part during fault recovery) is fully operational.
Time to Power Up to Level II	t_power_level2		300	ms	From falling edge of stop bit enabling power level II until non-cooled module is fully operational
Time to Power Down from Level II	t_power_down		300	ms	From falling edge of stop bit disabling power level II until module is within power level I requirements
TX_Fault assert	TX_Fault_on		1	ms	From occurrence of fault to assertion of TX_Fault
TX_Fault assert for cooled module	TX_Fault_on_cooled		50	ms	From occurrence of fault to assertion of TX_Fault
TX_Fault Reset	t_reset	10		μs	Time TX_Disable must be held high to reset TX_Fault
RS0, RS1 rate select timing for FC	t_RS0_FC, RS1_FC		500	μs	From assertion till stable output
RS0, RS1 rate select timing non FC	t_RS0, t_RS1		10	ms	From assertion till stable output
Rx_LOS assert delay	t_los_on		100	μs	From occurrence of loss of signal to assertion of Rx_LOS
Rx_LOS negate delay	t_los_off		100	μs	From occurrence of presence of signal to negation of Rx_LOS

Pin definition

The SFP+ modules are hot-pluggable. Hot pluggable refers to plugging in or unplugging a module while the host board is powered. The SFP+ host connector is a 0.8 mm pitch 20 position right angle improved connector specified by SFF-8083, or stacked connector with equivalent with equivalent electrical performance.

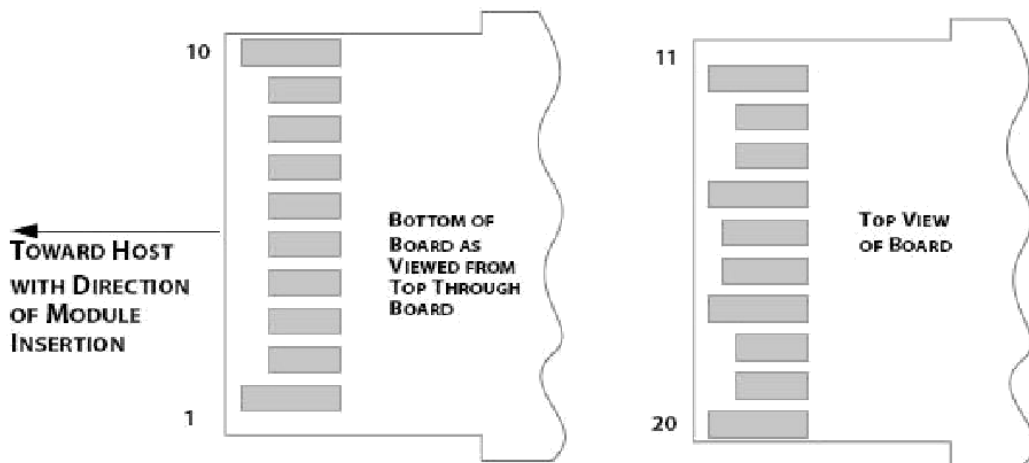
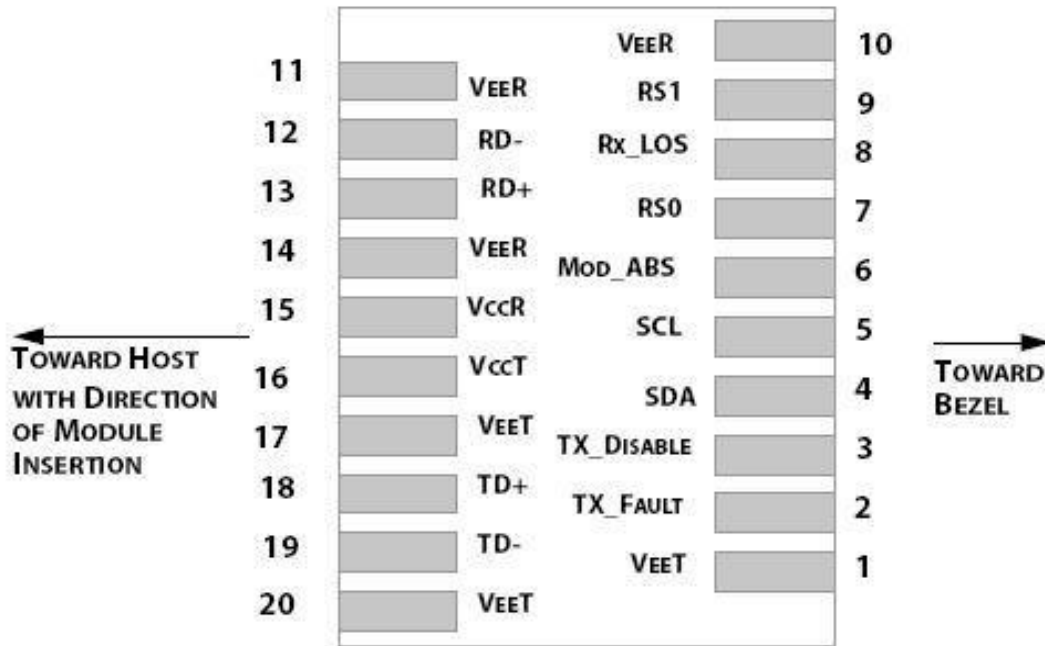

Module Contact Assignment

<i>Contacts</i>	<i>logic</i>	<i>Symbol</i>	<i>Power Sequence Order</i>	<i>Name/Description</i>
1		VeeT	1st	Module Transmitter Ground
2	LVTTL-O	TX_Fault	3rd	Module Transmitter Fault
3	LVTTL-I	TX_Disable	3rd	Transmitter Disable; Turns off transmitter laser output
4	LVTTL-I/O	SDA	3rd	2-wire Serial Interface Data Line (Same as MOD-DEF2 in the INF-8074i)
5	LVTTL-I/O	SCL	3rd	2-wire Serial Interface Clock (Same as MOD-DEF1 in the INF-8074i)
6		Mod_ABS	3rd	Module Absent, connected to VeeT or VeeR in the module
7	LVTTL-I	RS0	3rd	Rate Select 0, optionally controls SFP+ module receiver. When high input signaling rate > 4.25 GBd and when low input signaling rate ≤ 4.25 GBd.
8	LVTTL-O	Rx_LOS	3rd	Receiver Loss of Signal Indication (In FC designated as Rx_LOS and in Ethernet designated as <u>Signal Detect</u>)
9	LVTTL-I	RS1	3rd	Rate Select 1, optionally controls SFP+ transmitter. When high input signaling rate > 4.25 GBd and when low input signaling rate ≤ 4.25 GBd.
10		VeeR	1st	Module Receiver Ground
11		VeeR	1st	Module Receiver Ground
12	CML-O	RD-	3rd	Receiver Inverted Data Output
13	CML-O	RD+	3rd	Receiver Non-Inverted Data Output
14		VeeR	1st	Module Receiver Ground
15		VccR	2nd	Module Receiver 3.3 V Supply
16		VccT	2nd	Module Transmitter 3.3 V Supply
17		VeeT	1st	Module Transmitter Ground
18	CML-I	TD+	3rd	Transmitter Non-Inverted Data Input
19	CML-I	TD-	3rd	Transmitter Inverted Data Input
20		VeeT	1st	Module Transmitter Ground

Mechanical

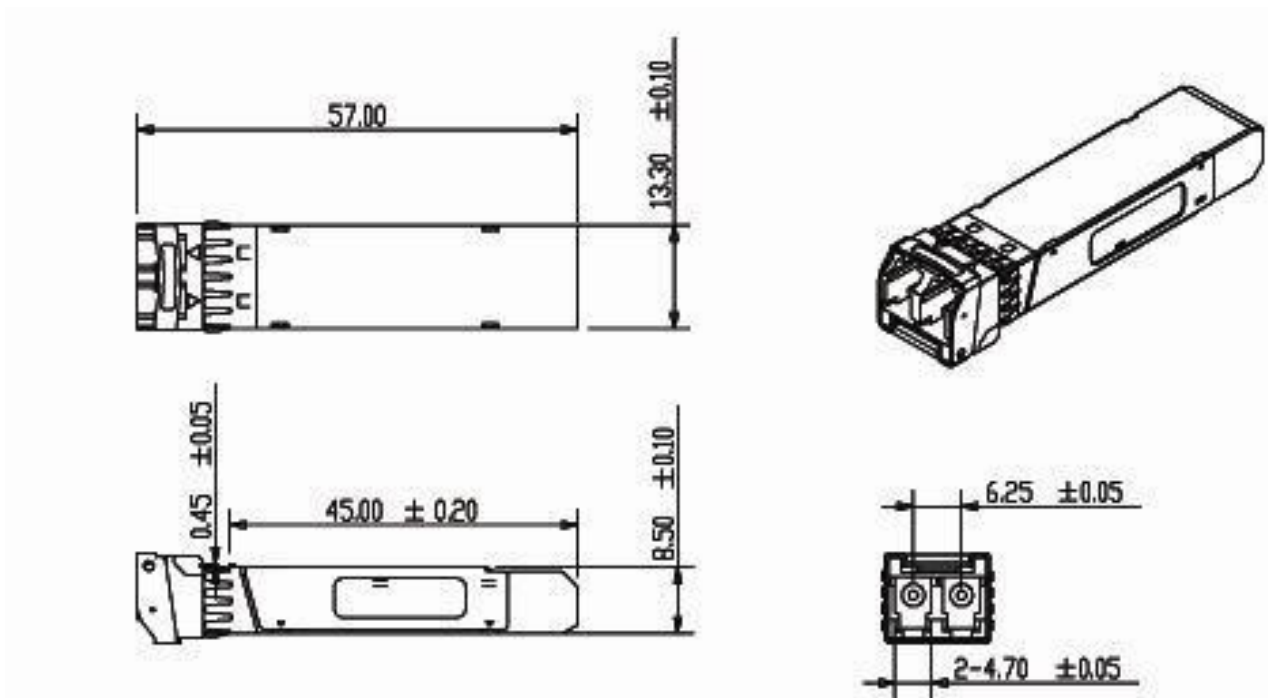

Table 9: Key Mechanical Dimensions

ESD

This transceiver is specified as ESD threshold 2kV for all electrical input pins, tested per MIL-STD-883, Method 3015.4 /JESD22-A114-A (HBM). However, normal ESD precautions are still required during the handling of this module. This transceiver is shipped in ESD protective packaging. It should be removed from the packaging and handled only in an ESD protected environment.

LASER SAFETY

This is a Class 1 Laser Product according to IEC 60825-1:1993:+A1:1997+A2:2001. This product complies with 21 CFR 1040.10 and 1040.11 except for deviations pursuant to Laser Notice No. 50, dated (July 26, 2001)

Ordering information

Part No.	Data Rate	Temperature	Tx/Rx Type	Distance
HOLS-PP131066-LD-CD	6G	-5°C to 70°C	1310nm DFB/PIN	10km
HOLS-PP131066-LD-ID	6G	-40°C to +85 °C	1310nm DFBL/PIN	10km

Warnings Handling Precautions: This device is susceptible to damage as a result of electrostatic discharge (ESD). A static free environment is highly recommended. Follow guidelines according to proper ESD procedures. **Laser Safety:** Radiation emitted by laser devices can be dangerous to human eyes. Avoid eye exposure to direct or indirect radiation.