

## FEATURES

- Supports up to 3.072Gb/s bit rates
- -20 to 75°C operating case temperature
- SFP package with single LC Receptacle connector
- 1510nm uncooled DFB laser transmitter and 1310nm PIN-TIA receiver
- Hot-pluggable capability
- Single 3.3V power supply
- Power dissipation<1W
- Up to 20km transmission distance over SMF
- Low EMI and excellent ESD protection
- Built- in Digital Diagnostic monitoring (DDM) function
- Class I laser product
- RoHS-6 compliance

## APPLICATIONS

- CPRI/OBSAI LINE at 1.2288Gbps, 2.4576Gbps, 3.072Gbps
- Digital repeater and Base station

## STANDARDS

- Complies with SFP Multi-Source Agreement (MSA) SFF-8074i
- Complies with SFF 8472 V9.5
- Complies with FCC 47 CFR Part 15, Class B
- Complies with 21 CFR 1040.10 and 1040.11 except for deviations pursuant to Laser Notice No. 50, dated June 24, 2007

**ABSOLUTE MAXIMUM RATING**

Parameter	Symbol	Min.	Max.	Unit	Notes
Storage Ambient Temperature	T <sub>STG</sub>	-40	85	°C	
Operating Case Temperature	T <sub>c</sub>	-20	75	°C	
Operating Humidity	OH	5	85	%	
Power Supply Voltage	V <sub>CC</sub>	-0.5	3.6	V	

**RECOMMENDED OPERATING CONDITION**

Parameter	Symbol	Min.	Typ.	Max.	Unit	Notes
Operating Case Temperature	T <sub>c</sub>	-20		+75	°C	
Power Supply Voltage	V <sub>CC</sub>	3.13	3.3	3.47	V	
Power Supply Current	I <sub>CC</sub>			300	mA	
Date Rate			3.072		Gbps	
Data Rate Drift		-100		+100	PPM	

**TRANSMITTER OPTICAL CHARACTERISTICS**

Parameter	Symbol	Min.	Typ.	Max.	Unit	Notes
Centre Wavelength	λ <sub>c</sub>	1502.5	1510	1517.5	nm	
Spectral Width (-20dB)				1	nm	
Average Output Power		-2		+3	dBm	Launched into SMF Fiber
Average Power of OFF Transmitter				-30	dBm	
Extinction Ratio	ER	6			dB	
Side Mode Suppression Ratio	SMSR	30			dB	

**TRANSMITTER ELECTRICAL CHARACTERISTICS**

Parameter	Symbol	Min.	Typ.	Max.	Unit	Notes
Data Input Differential Swing		200		2000	mV	
Input Differential Impedance		85	100	115	$\Omega$	
TX Disable	Disable	2		VCC	V	
	Enable	0		0.8	V	
TX Fault	Normal	0		0.4	V	
	Fault	2.4		VCC	V	

**RECEIVER OPTICAL CHARACTERISTICS**

Parameter	Symbol	Min.	Typ.	Max.	Unit	Notes
Operating Wavelength	$\lambda_c$	1300		1320	nm	
Sensitivity	SEN			-21	dBm	PRBS2 <sup>7</sup> -1 @3.072Gbps BER $\leq 1 \times 10^{-12}$
Saturation Optical Power	SAT	2			dBm	
LOS De-Assert	LOS <sub>D</sub>			-22	dBm	
LOS Assert	LOS <sub>A</sub>	-35			dBm	
LOS Hysteresis	HYS	0.5		5	dB	

**RECEIVER ELECTRICAL CHARACTERISTICS**

Parameter	Symbol	Min.	Typ.	Max.	Unit	Notes
Differential data output swing	Vout	350		850	mV	
Rx_LOS Output Voltage - High	High	2.4		Vcc	V	
Rx_LOS Output Voltage - Low	Low	0		0.4	V	
Output Rise Time, 20%~80%	TR			60	ps	
Output Fall Time, 20%~80%	TF			60	ps	

PIN DESCRIPTION			
PIN	Name	Description	Notes
1	V <sub>EE</sub> T	Transmitter Ground	
2	TX_Fault	Transmitter Fault Indication	Low: normal; High: abnormal
3	TX_Disable	Transmitter Disable	Low: transmitter on; High: transmitter off
4	SDA	SDA	The data line of two wire serial interface
5	SCL	SCL	The clock line of two wire serial interface
6	MOD_ABS	Module Absent	Connected to V <sub>EE</sub> T or V <sub>EE</sub> R in the module
7	Rate	Not Connected	
8	RX_LOS	Loss of Signal	Low: signal detected; High: loss of signal
9	V <sub>EE</sub> R	Receiver Ground	
10	V <sub>EE</sub> R	Receiver Ground	
11	V <sub>EE</sub> R	Receiver Ground	
12	RD-	Inv. Received Data Out	AC-coupled, CML
13	RD+	Received Data Out	AC-coupled, CML
14	V <sub>EE</sub> R	Receiver Ground	
15	V <sub>CC</sub> R	Receiver Power	
16	V <sub>CC</sub> T	Transmitter Power	
17	V <sub>EE</sub> T	Transmitter Ground	
18	TD+	Transmit Data In	AC-coupled, CML
19	TD-	Inv. Transmit Data In	AC-coupled, CML
20	V <sub>EE</sub> T	Transmitter Ground	

PIN OUT DRAWING (TOP VIEW)

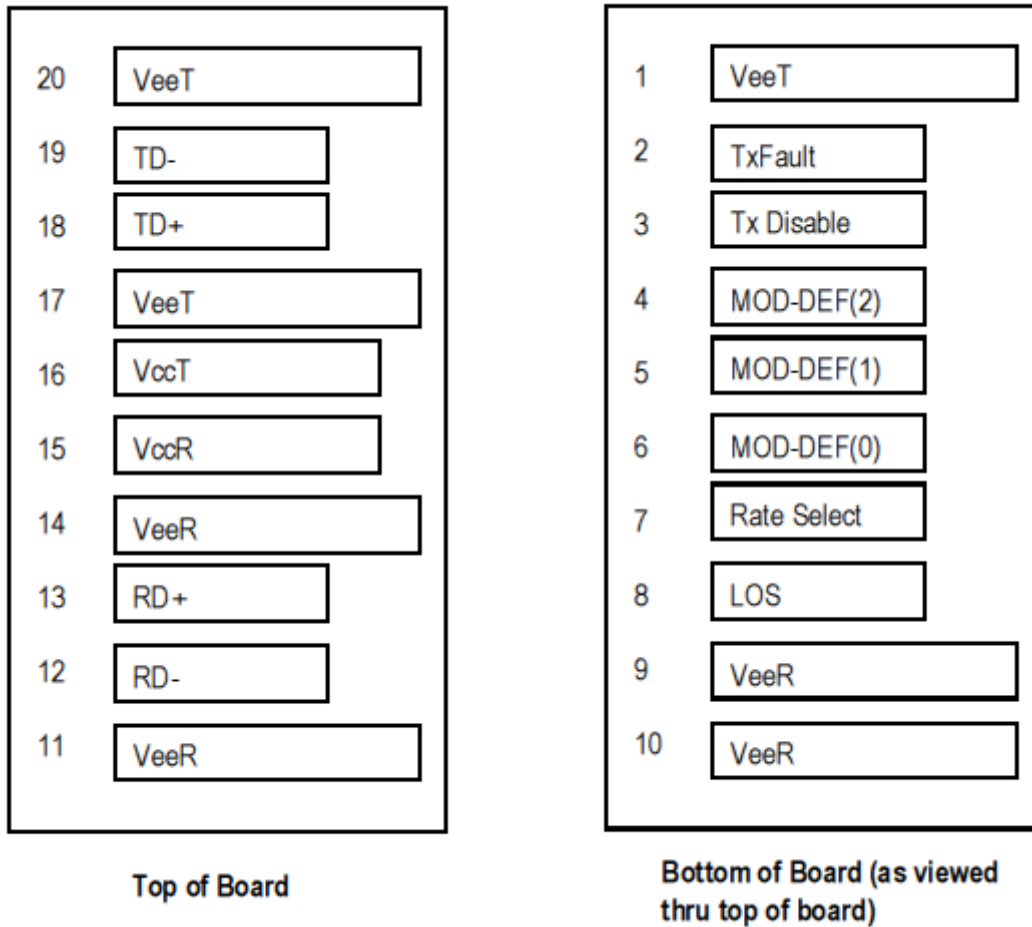

Figure 1 Pin Out Drawing (Top view)

TYPICAL INTERFACE CIRCUIT

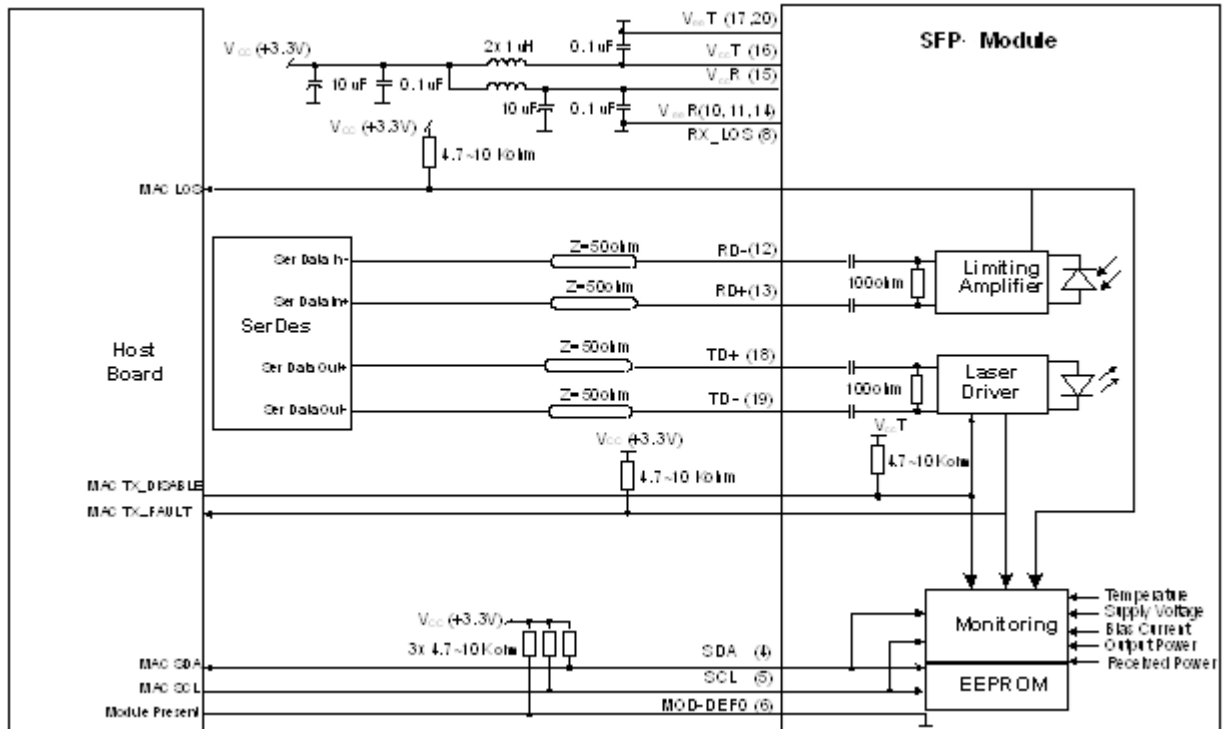

Figure 2 Typical Interface Circuit

PACKAGE OUTLINE

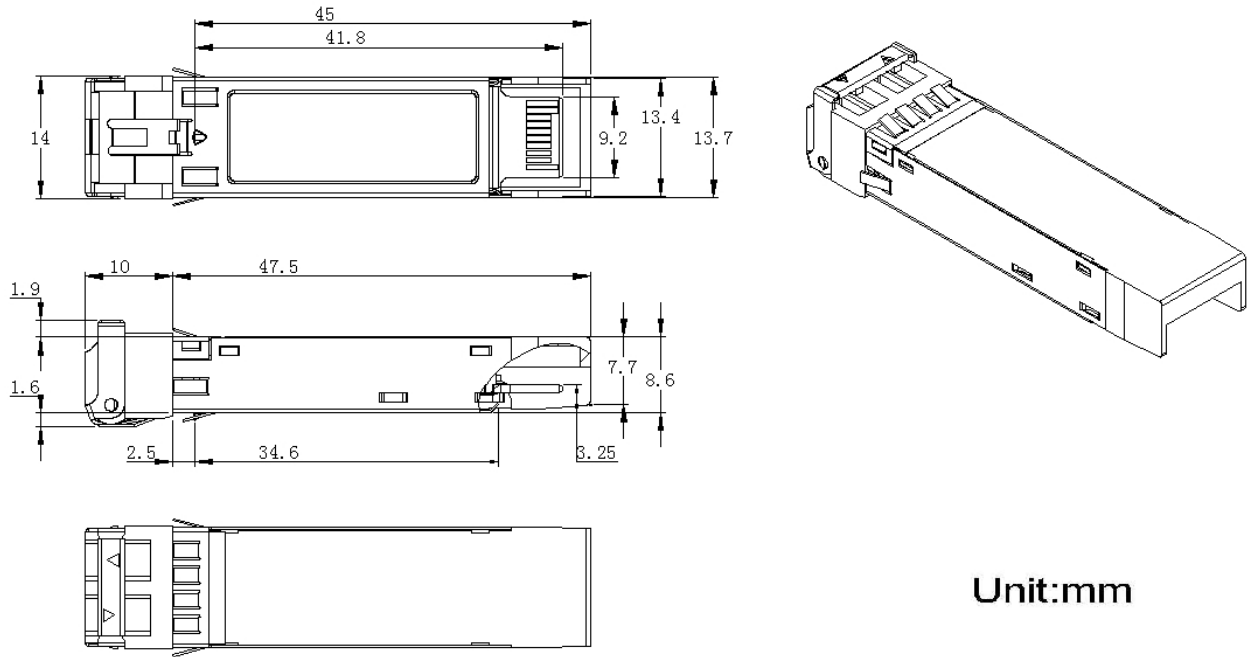

Figure 3 Package Outline

EEPROM INFORMATION

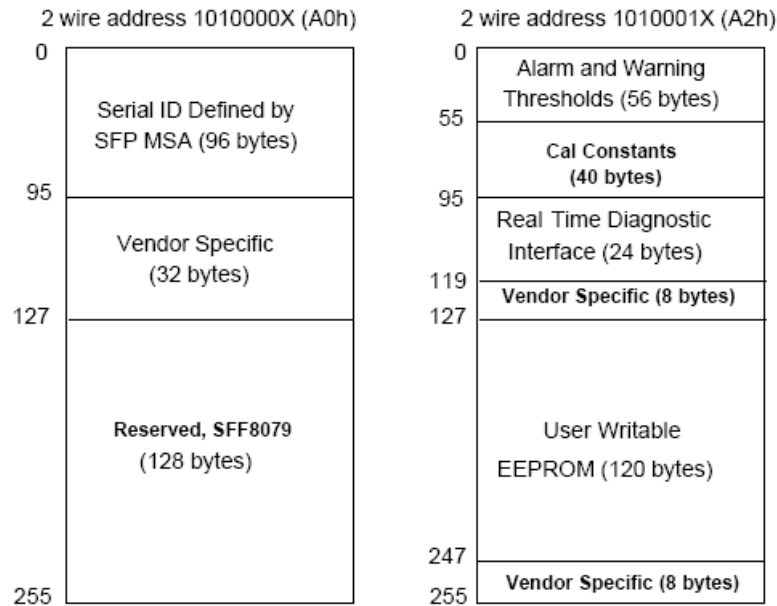

Figure 4 EEPROM Memory Map Specific Data Field Descriptions

#### DIGITAL DIAGNOSTIC MONITORING INTERFACE

Five transceiver parameter values are monitored. The following table defines the monitored parameter's accuracy.

Parameter	Range	Accuracy	Calibration
Temperature	-20 to 75°C	±3°C	Internal
Voltage	2.97 to 3.63V	±3%	Internal
Bias Current	0 to 90mA	±10%	Internal
TX Power	-4 to +3dBm	±2dB	Internal
RX Power monitor	-23 to +3dBm	±2dB	Internal

#### WARNINGS

- Handling Precautions: This device is susceptible to damage as a result of electrostatic discharge (ESD). A static free environment is highly recommended. Follow guidelines according to proper ESD procedures.
- Laser Safety: Radiation emitted by laser devices can be dangerous to human eyes. Avoid eye exposure to direct or indirect radiation.