

FEATURES

- Supports up to 3.072Gb/s bit rates
- -20 to 75°C operating case temperature
- SFP package with single LC Receptacle connector
- 1310nm uncooled DFB laser transmitter and 1510nm PIN-TIA receiver
- Hot-pluggable capability
- Single 3.3V power supply
- Power dissipation<1W
- Up to 20km transmission distance over SMF
- Low EMI and excellent ESD protection
- Built- in Digital Diagnostic monitoring (DDM) function
- Class I laser product
- RoHS-6 compliance

APPLICATIONS

- CPRI/OBSAI LINE at 1.2288Gbps, 2.4576Gbps, 3.072Gbps
- Digital repeater and Base station

STANDARDS

- Complies with SFP Multi-Source Agreement (MSA) SFF-8074i
- Complies with SFF 8472 V9.5
- Complies with FCC 47 CFR Part 15, Class B
- Complies with 21 CFR 1040.10 and 1040.11 except for deviations pursuant to Laser Notice No. 50, dated June 24, 2007

ABSOLUTE MAXIMUM RATING

| Parameter | Symbol | Min. | Max. | Unit | Notes |
|-----------------------------|------------------|------|------|------|-------|
| Storage Ambient Temperature | T _{STG} | -40 | 85 | °C | |
| Operating Case Temperature | T _c | -20 | 75 | °C | |
| Operating Humidity | OH | 5 | 85 | % | |
| Power Supply Voltage | V _{CC} | -0.5 | 3.6 | V | |

RECOMMENDED OPERATING CONDITION

| Parameter | Symbol | Min. | Typ. | Max. | Unit | Notes |
|----------------------------|-----------------|------|-------|------|------|-------|
| Operating Case Temperature | T _c | -20 | | +75 | °C | |
| Power Supply Voltage | V _{CC} | 3.13 | 3.3 | 3.47 | V | |
| Power Supply Current | I _{CC} | | | 300 | mA | |
| Data Rate | | | 3.072 | | Gbps | |
| Data Rate Drift | | -100 | | +100 | PPM | |

TRANSMITTER OPTICAL CHARACTERISTICS

| Parameter | Symbol | Min. | Typ. | Max. | Unit | Notes |
|----------------------------------|----------------|--------|------|--------|------|-------------------------|
| Centre Wavelength | λ _c | 1302.5 | 1310 | 1317.5 | nm | |
| Spectral Width (-20dB) | | | | 1 | nm | |
| Average Output Power | | -2 | | +3 | dBm | Launched into SMF Fiber |
| Average Power of OFF Transmitter | | | | -30 | dBm | |
| Extinction Ratio | ER | 6 | | | dB | |
| Side Mode Suppression Ratio | SMSR | 30 | | | dB | |

TRANSMITTER ELECTRICAL CHARACTERISTICS

| Parameter | Symbol | Min. | Typ. | Max. | Unit | Notes |
|-------------------------------|---------|------|------|------|----------|-------|
| Data Input Differential Swing | | 200 | | 200 | mV | |
| Input Differential Impedance | | 85 | 100 | 115 | Ω | |
| TX Disable | Disable | 2 | | VCC | V | |
| | Enable | 0 | | 0.8 | V | |
| TX Fault | Normal | 0 | | 0.4 | V | |
| | Fault | 2.4 | | VCC | V | |

RECEIVER OPTICAL CHARACTERISTICS

| Parameter | Symbol | Min. | Typ. | Max. | Unit | Notes |
|--------------------------|------------------|------|------|------|------|---|
| Operating Wavelength | λ_C | 1500 | | 1520 | nm | |
| Sensitivity | SEN | | | -21 | dBm | PRBS2 ⁷ -1 @3.072Gbps BER $\leq 1 \times 10^{-12}$ |
| Saturation Optical Power | SAT | 2 | | | dBm | |
| LOS De-Assert | LOS _D | | | -22 | dBm | |
| LOS Assert | LOS _A | -35 | | | dBm | |
| LOS Hysteresis | HYS | 0.5 | | 5 | dB | |

RECEIVER ELECTRICAL CHARACTERISTICS

| Parameter | Symbol | Min. | Typ. | Max. | Unit | Notes |
|--------------------------------|------------------|------|------|-----------------|------|-------|
| Differential data output swing | V _{out} | 350 | | 850 | mV | |
| Rx_LOS Output Voltage - High | High | 2.4 | | V _{cc} | V | |
| Rx_LOS Output Voltage - Low | Low | 0 | | 0.4 | V | |
| Output Rise Time, 20%~80% | TR | | | 60 | ps | |
| Output Fall Time, 20%~80% | TF | | | 60 | ps | |

| PIN DESCRIPTION | | | |
|-----------------|-------------------|------------------------------|---|
| PIN | Name | Description | Notes |
| 1 | V _{EE} T | Transmitter Ground | |
| 2 | TX_Fault | Transmitter Fault Indication | Low: normal; High: abnormal |
| 3 | TX_Disable | Transmitter Disable | Low: transmitter on; High: transmitter off |
| 4 | SDA | SDA | The data line of two wire serial interface |
| 5 | SCL | SCL | The clock line of two wire serial interface |
| 6 | MOD_ABS | Module Absent | Connected to V _{EE} T or V _{EE} R in the module |
| 7 | Rate | Not Connected | |
| 8 | RX_LOS | Loss of Signal | Low: signal detected; High: loss of signal |
| 9 | V _{EE} R | Receiver Ground | |
| 10 | V _{EE} R | Receiver Ground | |
| 11 | V _{EE} R | Receiver Ground | |
| 12 | RD- | Inv. Received Data Out | AC-coupled, CML |
| 13 | RD+ | Received Data Out | AC-coupled, CML |
| 14 | V _{EE} R | Receiver Ground | |
| 15 | V _{CC} R | Receiver Power | |
| 16 | V _{CC} T | Transmitter Power | |
| 17 | V _{EE} T | Transmitter Ground | |
| 18 | TD+ | Transmit Data In | AC-coupled, CML |
| 19 | TD- | Inv. Transmit Data In | AC-coupled, CML |
| 20 | V _{EE} T | Transmitter Ground | |

PIN OUT DRAWING (TOP VIEW)

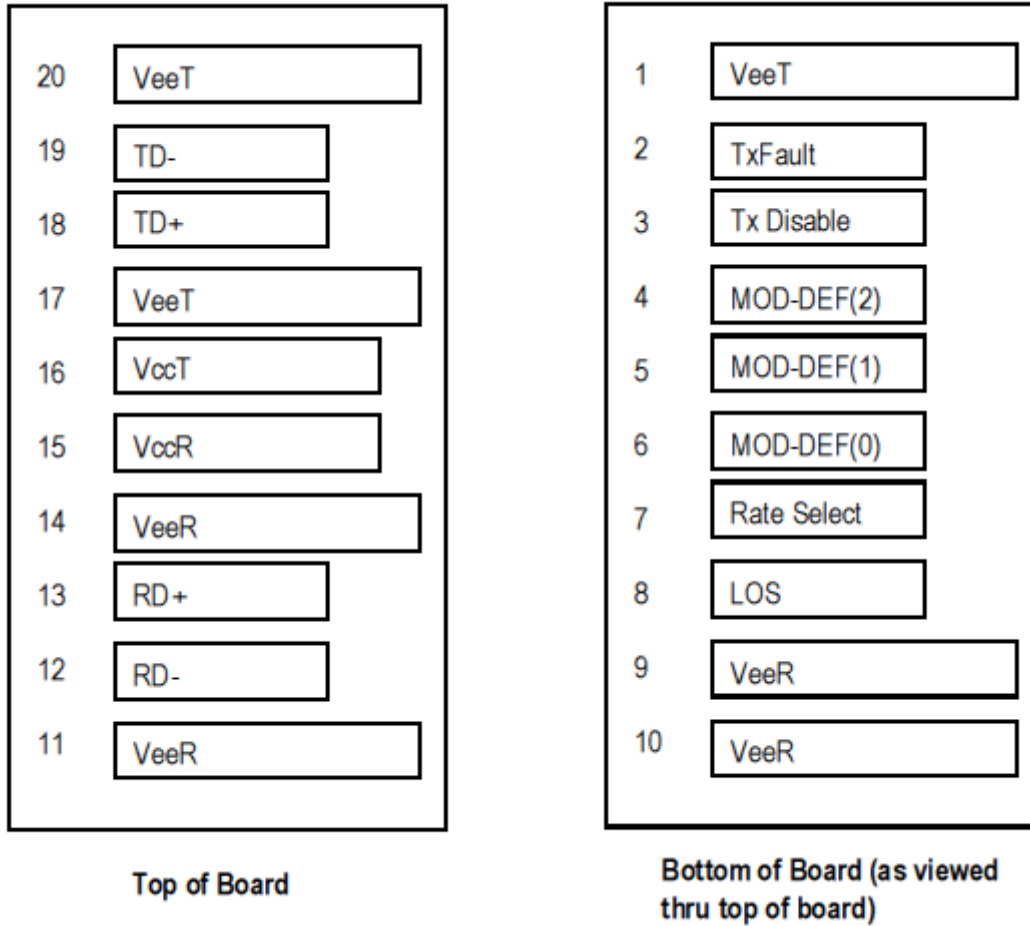

Figure 1 Pin Out Drawing (Top view)

TYPICAL INTERFACE CIRCUIT

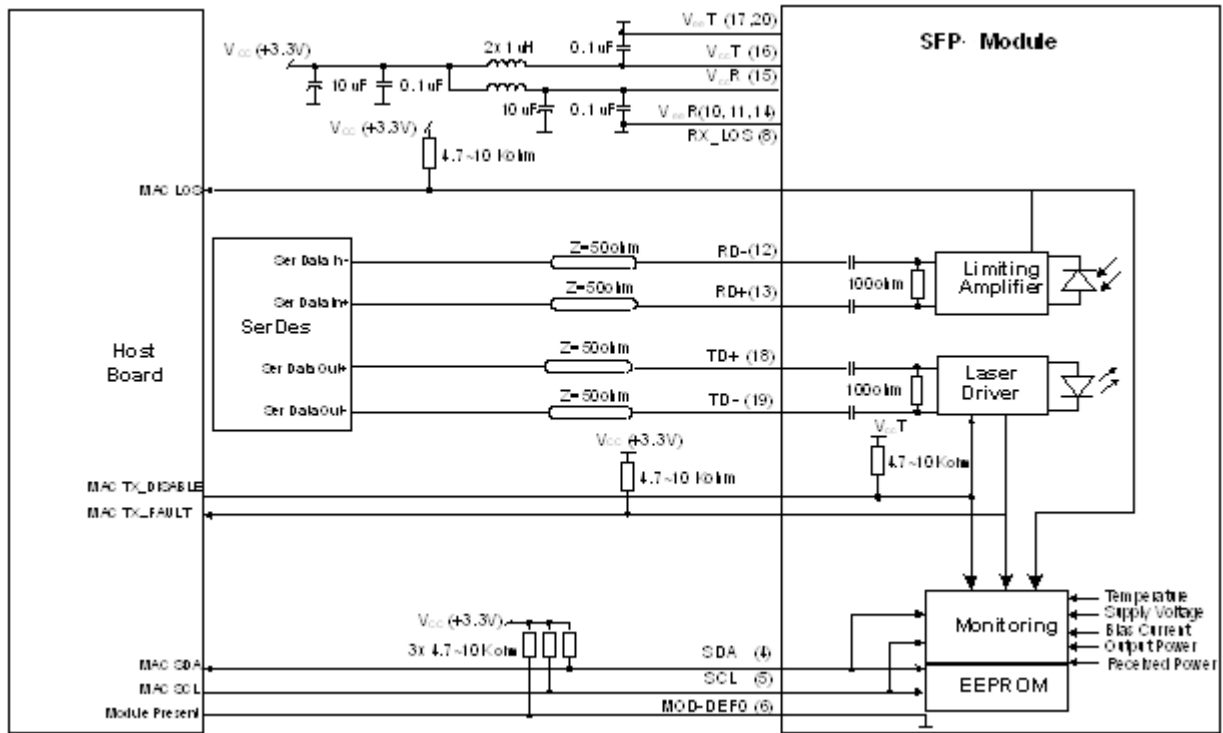

Figure 2 Typical Interface Circuit

PACKAGE OUTLINE

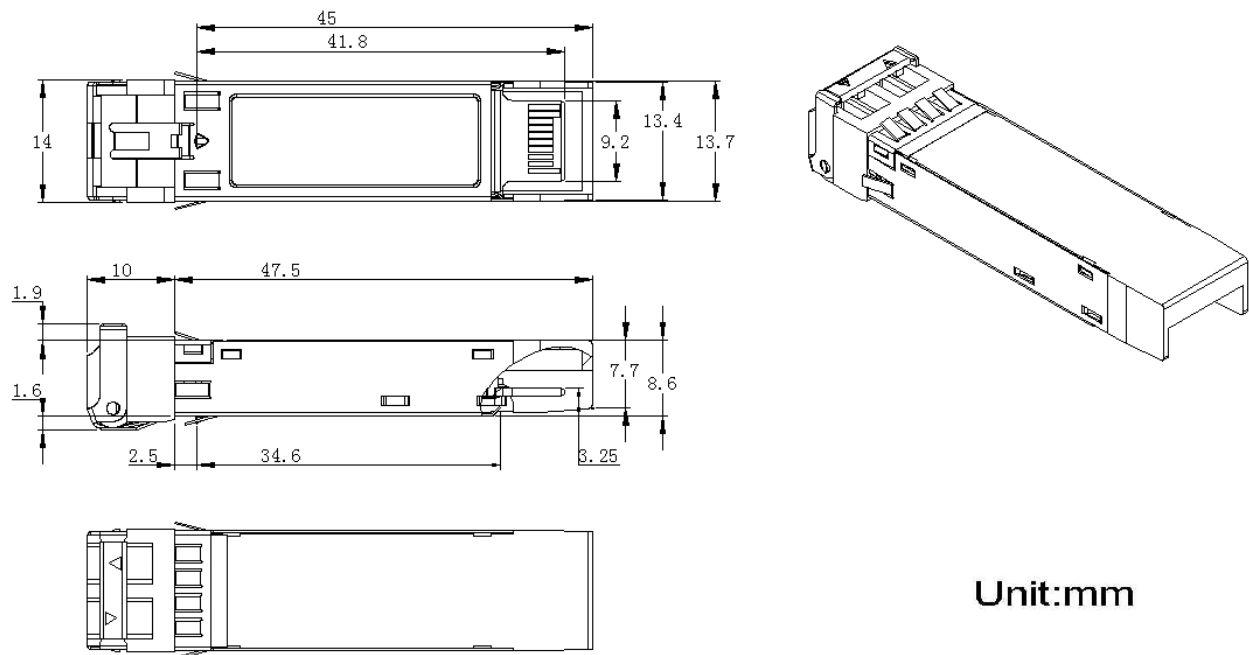

Figure 3 Package Outline

EEPROM INFORMATION

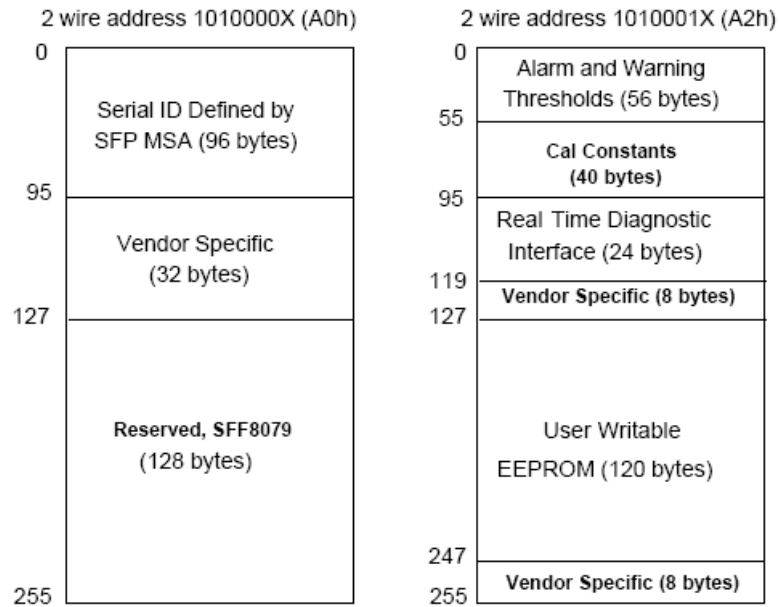

Figure 4 EEPROM Memory Map Specific Data Field Descriptions

DIGITAL DIAGNOSTIC MONITORING INTERFACE

Five transceiver parameter values are monitored. The following table defines the monitored parameter's accuracy.

| Parameter | Range | Accuracy | Calibration |
|------------------|---------------|----------|-------------|
| Temperature | -20 to 75°C | ±3°C | Internal |
| Voltage | 2.97 to 3.63V | ±3% | Internal |
| Bias Current | 0 to 90mA | ±10% | Internal |
| TX Power | -4 to +3dBm | ±2dB | Internal |
| RX Power monitor | -23 to +3dBm | ±2dB | Internal |

WARNINGS

- Handling Precautions: This device is susceptible to damage as a result of electrostatic discharge (ESD). A static free environment is highly recommended. Follow guidelines according to proper ESD procedures.
- Laser Safety: Radiation emitted by laser devices can be dangerous to human eyes. Avoid eye exposure to direct or indirect radiation.