

3.125Gbps Single Wavelength BiDi SFP CWDM Transceiver

Product Features

- 18 CWDM wavelengths available
- Single wavelength bi-directional
- CWDM DFB Laser Transmitter and PIN Receiver
- Compliant with SFP MSA and SFF-8472 with FC/APC Pigtail
- Hot-pluggable
- Single +3.3 Power Supply
- Compliant with Telcordia (Bellcore) GR-468-CORE
- Up to 3.125Gbps data links
- Pigtail with FC/APC connector
- Maximal reach 20km
- RoHS-6 compliance

Product Applications

- Fiber Channel

General

The SFP transceivers consists of three sections: an uncooled CWDM DFB laser transmitter, a PIN photodiode integrated with a trans-impedance preamplifier (TIA) and MCU control unit. The products are compliant with the Small Form- Factor Pluggable (SFP) Multi-Source Agreement (MSA) and SFF-8472. The Digital Diagnostic Monitoring functions as described in SFF-8472 are provided via an I2C serial interface. The transceiver block diagram is shown as below Fig 1.

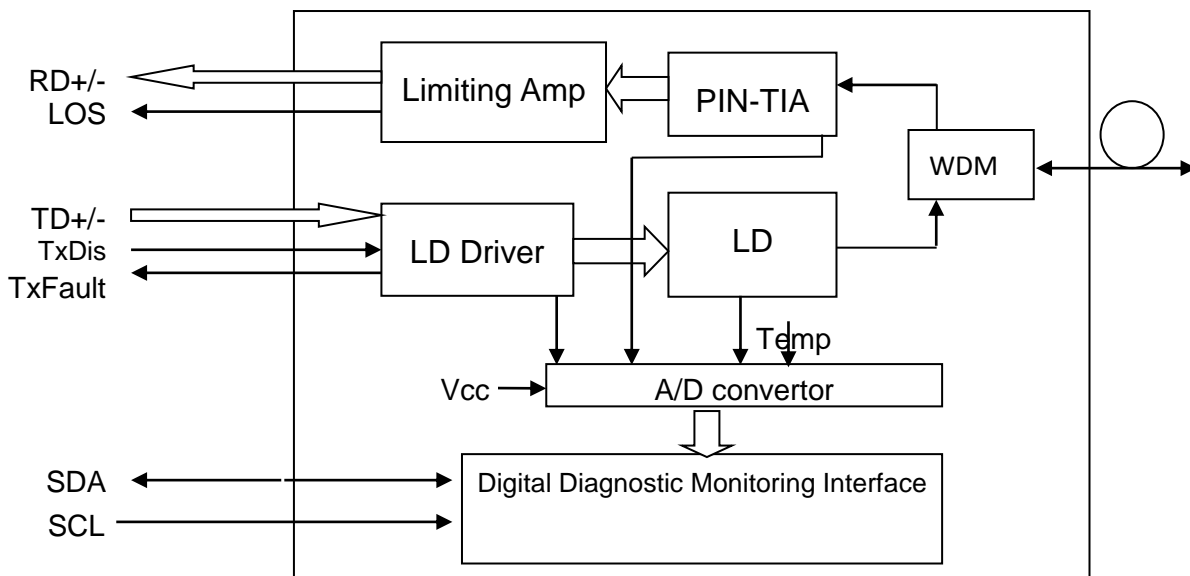

Fig 1 Transceiver Block Diagram

The module provides digital diagnostic information of its operating conditions and status, including transmitting power, laser bias, receiver input optical power, module temperature, and supply voltage. Calibration and

alarm/warning threshold data are written and stored in internal memory (EEPROM). The memory map is compatible with SFF-8472, as shown in Fig. 2. The diagnostic data are raw A/D values and must be converted to real world units using calibration constants stored in EEPROM locations 56 – 95 in A2h.

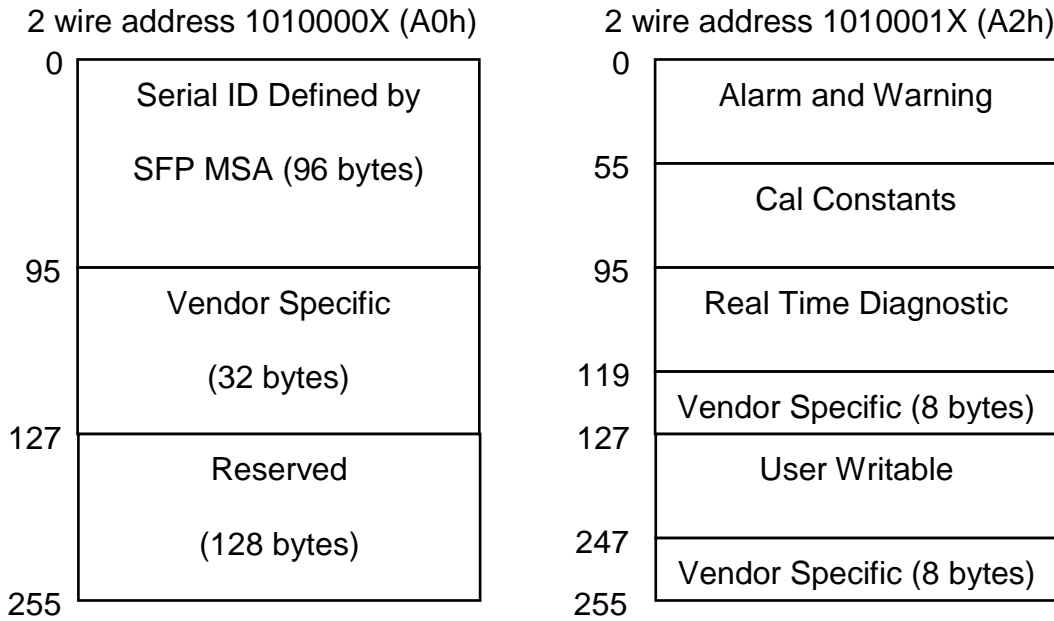

Fig 2 EEPROM Information

Performance Specifications

Absolute Maximum Ratings					
Parameter	Symbol	Min.	Max.	Unit	Note
Storage Temperature	Tst	-40	+85	°C	
Operating Case Temperature	Tc	0	70	°C	HOLS-P3Cxxxx2A-FD-CD
		-40	85		HOLS-P3Cxxxx2A-FD-ID
Input Voltage	-	GND	Vcc	V	
Power Supply Voltage	Vcc-Vee	-0.5	+3.6	V	

Recommended Operating Conditions						
Parameter	Symbol	Min.	Typical	Max.	Unit	Note
Power Supply Voltage	Vcc	3.135	3.3	3.465	V	-
Operating Case Temperature	Tc	0	-	70	°C	HOLS-P3Cxxxx2A-FD-CD

		-40	-	85		HOLS-P3Cxxxx2A-FD-ID
Data Rate	DR	-	-	3.125	Gbps	-
Total Supply Current	-	-	-	300	mA	-
Electrical-Optical Specification						
Transmitter						
Parameter	Symbol	Min.	Typ.	Max.	Unit	Note
Optical Central Wavelength	λ_c	$\lambda_c-6.5$	λ_c	$\lambda_c+6.5$	nm	1
Spectral Width(-20dB)	$\Delta\lambda$	-	-	1	nm	
Side Mode Suppression Ratio	SMSR	30	-		dB	
Average Optical Output Power	Po	-7	-	-3	dBm	
Extinction Ratio	Er	6.5	-	-	dB	
Optical Rise/Fall Time	Tr/Tf	-	-	180	ps	
Transmitter Off Power	Poff	-	-	-45	dBm	
Relative Intensity Noise	RIN	-	-	-117	dB/Hz	
Total Jitter Generation	Jp-p	-	-	0.07	UI	
Dispersion Penalty	DP	-	-	1	dB	
Tx Enable Voltage	Ten	0	-	0.8	V	
Tx Disable Voltage	Tdis	2.4	-	3.3	V	
Differential Input Voltage	VPP-DIF	500	-	2400	mV	-
Output Eye	Compliant with ITU recommendation G.957					
Optical- Electrical Specification						
Receiver						
Parameter	Symbol	Min.	Typ.	Max.	Unit	Note
Operate Wavelength	-	λ_c-20	λ_c	λ_c+20	nm	1
Sensitivity	Pr	-	-	-18	dBm	2
Saturation	Ps	0.5	-	-	dBm	2
LOS De-assert Level	-	-	-	-18	dBm	-
LOS Assert Level	-	-35	-	-		
LOS Hysteresis	-	0.5	-	5	dB	-
Receiver Reflectance	-	-	-	-60	dB	-
Data Output Rise/Fall Time	Rr/Rf	-	-	180	ps	
Differential Data Output Voltage	VPP-DIF	370	-	2000	mV	-

LOS Output Voltage-Low	V _{OL}	-	-	0.8	V	
LOS Output Voltage-High	V _{OH}	2.0	-	-	V	

Note:

- The CWDM transceiver center wavelengths λ_c are: 1270,1290,1310,1330,1350,1370,1390,1410,1430,1450, 1470, 1490, 1510, 1530, 1550, 1570, 1590, 1610nm
- Measured with 2²³-1 NRZ PRBS. BER \leq 10⁻¹⁰ 3.125Gpbs, ER=9dB

EEPROM Information

EEPROM Serial ID Memory Contents (A0h)

Addr. (decimal)	Field Size (Bytes)	Name of Field	Content (Hex)	Content (Decimal)	Description
0	1	Identifier	03	3	SFP
1	1	Ext. Identifier	04	4	MOD4
2	1	Connector	0B	11	Optical Pigtail
3-10	8	Transceiver	00 xx 00 00 00 00 00 00	00 xx 00 00 00 00 00 00	Transmitter Code
11	1	Encoding	03	3	NRZ
12	1	BR, nominal	1F	31	3.125Gbps
13	1	Reserved	00	0	-
14	1	Length (9um)-km	14	20	20km
15	1	Length (9um)	C8	200	20km
16	1	Length (50um)	00	0	-
17	1	Length (62.5um)	00	0	-
18	1	Length (copper)	00	0	-
19	1	Reserved	00	0	-
20-35	16	Vendor name	xxx	xxx	'Honlus' (ASCII)
36	1	Reserved	00	0	-
37-39	3	Vendor OUI	00 00 00	0 0 0	-
40-55	16	Vendor PN	xxx	xxx	'HOLS-P3Cxxxx2A-FD-xD' (ASCII)
56-59	4	Vendor rev	30 30 30 20	48 48 48 32	"000" (ASCII)

60-61	2	Wavelength	Xx	xx	xx
62	1	Reserved	00	0	-
63	1	CC BASE	-	-	Check sum of bytes 0 - 62
64	1	Reserved	00	0	
65	1	Options	1A	26	
66	1	BR, max	00	0	-
67	1	BR, min	00	0	-
68-83	16	Vendor SN	-	-	ASCII
84-91	8	Vendor date	-	-	Year (2 bytes), Month (2 bytes), Day (2 bytes)
92	1	DDM Type	58/68	88/104	External/Internal Calibrated
93	1	Enhanced Option	B0	176	LOS, TX_FAULT and Alarm/warning flags implemented
94	1	SFF-8472 Compliance	02	2	SFF-8472 Rev10.3
95	1	CC EXT	-	-	Check sum of bytes 64 – 94
96-255	160	Vendor spec			

Alarm and Warning Thresholds (Serial ID A2H)

Parameter(Unit)	C Temp(°C)	I Temp(°C)	Voltage (V)	Bias (mA)	TX Power (dBm)	RX Power (dBm)
High Alarm	100	100	3.6	90	-3	0.5
Low Alarm	-10	-40	3	0	-7	-18
High Warning	95	95	3.5	70	-4	-0.5
Low Warning	0	-30	3.1	0	-6	-17

Digital Diagnostic Monitor Accuracy

Parameter	Unit	Accuracy	Range	Calibration
Tx Optical Power	dB	±2	Po: -Pomin~Pomax dBm, Recommended operation conditions	External/Internal
Rx Optical Power	dB	-3~0	Pi: Ps~Pr dBm, Recommended operation conditions	External/Internal
Bias Current	%	±10	Id: 1-100mA, Recommended operating conditions	External/Internal
Power Supply Voltage	%	±3	Recommended operating conditions	External/Internal

Internal Temperature	°C	±3	Recommended operating conditions	External/Internal
----------------------	----	----	----------------------------------	-------------------

PIN Diagram

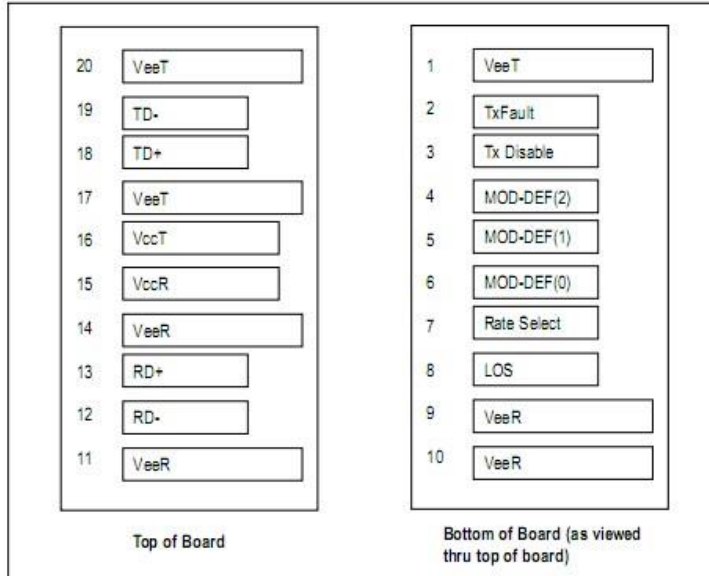

PIN Description

Pin No.	Name	Function	Plug Seq.	Notes
1	VeeT	Transmitter Ground	1	
2	Tx Fault	Transmitter Fault Indication	3	Note 1
3	Tx Disable	Transmitter Disable	3	Note 2
4	MOD-DEF2	Module Definition 2	3	Note 3
5	MOD-DEF1	Module Definition 1	3	Note 3
6	MOD-DEF0	Module Definition 0	3	Note 3
7	Rate Select	NC	3	
8	LOS	Los Of Signal	3	Note 4
9	VeeR	Receiver Ground	1	Note 5
10	VeeR	Receiver Ground	1	Note 5
11	VeeR	Receiver Ground	1	Note 5
12	RD-	Inv. Receiver Data Out	3	Note 6
13	RD+	Receiver Data Out	3	Note 6
14	VeeR	Receiver Ground	1	Note 5
15	VccR	Receiver Power Supply	2	Note 7, 3.3V± 5%
16	VccT	Transmitter Power Supply	2	Note 7, 3.3V± 5%
17	VeeT	Transmitter Ground	1	Note 5
18	TD+	Transmitter Data In	3	Note 8

19	TD-	Inv.Transmitter Data In	3	Note 8
20	VeeT	Transmitter Ground	1	Note 5

Notes:

- TX Fault is an open collector/drain output, which should be pulled up with a 4.7K–10KΩ resistor on the host board. Pull up voltage between 2.0V and VccT, R+0.3V. When high, output indicates a laser fault of some kind. Low indicates normal operation. In the low state, the output will be pulled to < 0.8V.
- TX disable is an input that is used to shut down the transmitter optical output. It is pulled up within the module with a 4.7–10 KΩ resistor. Its states are:
 - Low (0 – 0.8V): Transmitter on
 - (>0.8, < 2.0V): Undefined
 - High (2.0 – 3.465V): Transmitter Disabled
 - Open: Transmitter Disabled
- Mod-Def 0,1,2. These are the module definition pins. They should be pulled up with a 4.7K – 10KΩ resistor on the host board. The pull-up voltage shall be VccT or VccR.
 - Mod-Def 0 is grounded by the module to indicate that the module is present
 - Mod-Def 1 is the clock line of two wire serial interface for serial ID
 - Mod-Def 2 is the data line of two wire serial interface for serial ID
- LOS (Loss of Signal) is an open collector/drain output, which should be pulled up with a 4.7K – 10KΩ resistor. Pull up voltage between 2.0V and VccT, R+0.3V. When high, this output indicates the received optical power is below the worst-case receiver sensitivity (as defined by the standard in use). Low indicates normal operation. In the low state, the output will be pulled to < 0.8V.
- VeeR and VeeT may be internally connected within the SFP module.
- RD-/+ : These are the differential receiver outputs. They are AC coupled 100Ω differential lines which should be terminated with 100Ω (differential) at the user SERDES. The AC coupling is done inside the module and is thus not required on the host board.
- VccR and VccT are the receiver and transmitter power supplies. They are defined as 3.3V ±5% at the SFP connector pin. Maximum supply current is 300mA. Recommended host board power supply filtering is shown below. Inductors with DC resistance of less than 1Ω should be used in order to maintain the required voltage at the SFP input pin with 3.3V supply voltage. When the recommended supply filtering network is used, hot plugging of the SFP transceiver module will result in an inrush current of no more than 30 mA greater than the steady state value. VccR and VccT may be internally connected within the SFP transceiver module.
- TD-/+ : These are the differential transmitter inputs. They are AC-coupled, differential lines with 100Ω differential termination inside the module. The AC coupling is done inside the module and is thus not required on the host board.

Recommended Circuit

Recommended Host Board Supply Filtering Network

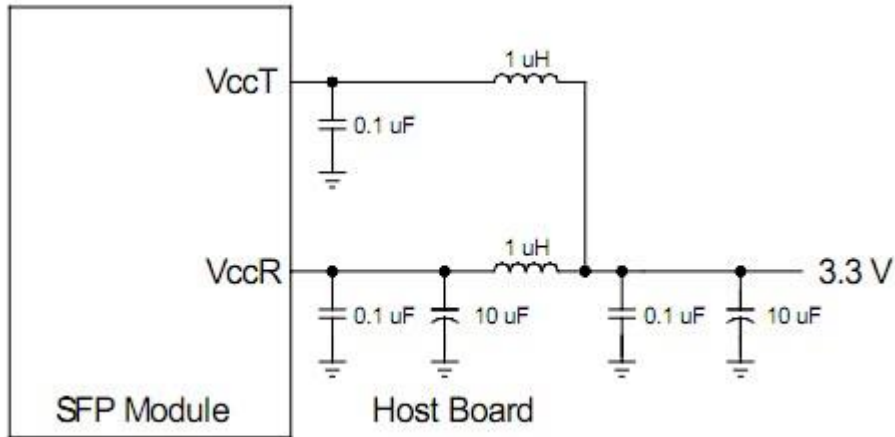

Example SFP Host Board Schematic

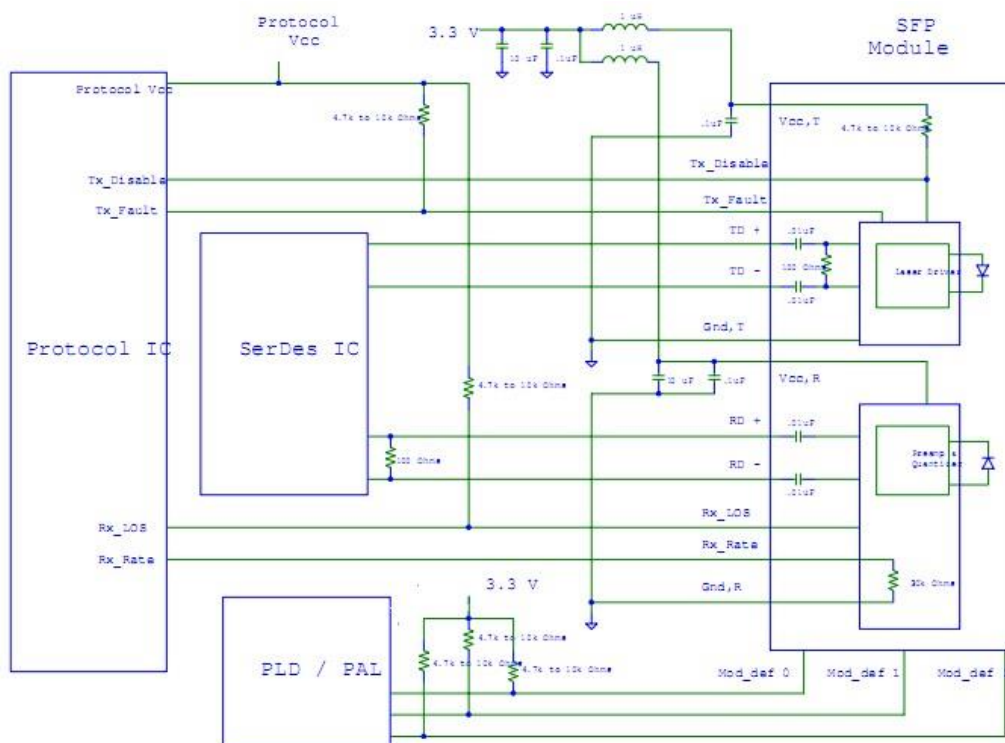

Package Diagram

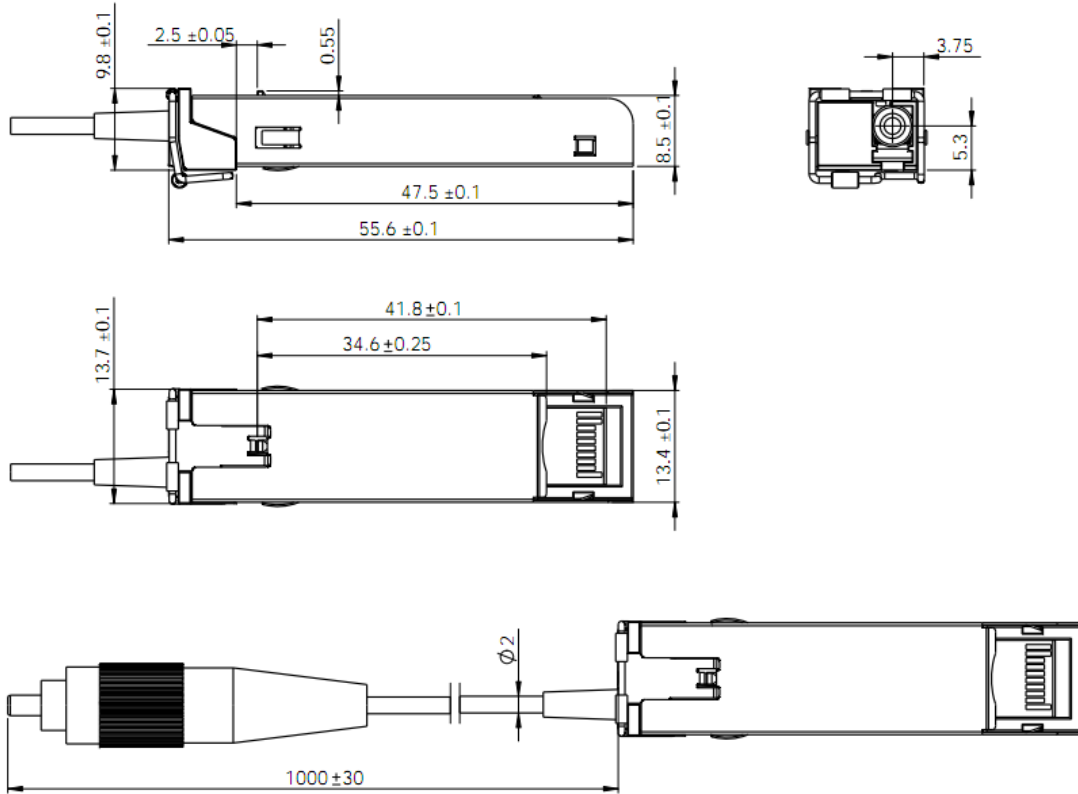

Unit: mm

Wavelength code

Center Wavelength(nm)	Code	Center Wavelength(nm)	Code
1270	27	1450	45
1290	29	1470	47
1310	31	1490	49
1330	33	1510	51
1350	35	1530	53
1370	37	1550	55
1390	39	1570	57
1410	41	1590	59
1430	43	1610	61