

FEATURES

- Dual GbE in one C-SFP form factor
- Two single fiber bi-directional data links symmetric 1.25Gbps application
- 1310nm FP transmitter, 850nm PIN-TIA receiver
- 0 to 70°C operating case temperature
- SFP+ package with duplex LC/PC MMF receptacle connector
- Up to 50m on each MMF(OM1, 62.5/125µm MMF), Up to 200m on each MMF(OM3, 50/125µm MMF)
- Hot-pluggable capability
- Single 3.3V power supply
- Built-in Digital Diagnostic monitoring (DDM) function
- Low EMI and excellent ESD protection
- Class I laser safety standard IEC-60825 compliant
- RoHS-6 compliance



APPLICATIONS

- CPRI 1.2288Gbps
- Gigabit Ethernet 1.25Gbps
- Switch to switch interface
- Switched backplane applications
- High Speed Interface for server farms

STANDARDS

- Complies with SFP+ MSA (SFF-8431)
- Complies with SFF-8472 Rev 10.4
- Complies with FCC 47 CFR Part 15, Class B
- Complies with 21 CFR 1040.10 and 1040.11 except for deviations pursuant to Laser Notice No. 50, dated June 24, 2007

ABSOLUTE MAXIMUM RATING

Parameter	Symbol	Min.	Max.	Unit	Notes
Storage Ambient Temperature	T _{STG}	-40	85	°C	
Operating Case Temperature	T _c	0	70	°C	
Operating Humidity	OH	5	95	%	
Power Supply Voltage	V _{CC}	0	4	V	
Receiver Damaged Threshold		+4		dBm	

RECOMMENDED OPERATING CONDITION

Parameter	Symbol	Min.	Typ.	Max.	Unit	Notes
Operating Case Temperature	T _c	0		70	°C	
Power Supply Voltage	V _{CC}	3.13	3.3	3.47	V	
Power Supply Current	I _{CC}		200	300	mA	
Date Rate		1.2288		1.25	Gbps	
Data Rate Drift		-100		+100	PPM	

TRANSMITTER OPTICAL CHARACTERISTICS

Parameter	Symbol	Min.	Typ.	Max.	Unit	Notes
Centre Wavelength	λ _c	1260	1310	1360	nm	
Spectral Width (RMS)				3	nm	
Average Output Power	P _o	-3.0		1	dBm	
Burst off Average Output Power				-45	dBm	
Extinction Ratio	ER	9			dB	
Optical Return Loss Tolerance				12	dB	
RIN _{15OMA}				-115	dB/Hz	

TRANSMITTER ELECTRICAL CHARACTERISTICS

Parameter	Symbol	Min.	Typ.	Max.	Unit	Notes
Data Input Differential Swing		200		1200	mV	CML input, AC coupled
Input Differential Impedance		90	100	110	Ω	
TX Disable	Disable	2		VCC	V	
	Enable	0		0.8	V	
TX Fault	Normal	2.4		VCC	V	
	Fault	0		0.4	V	

RECEIVER OPTICAL CHARACTERISTICS

Parameter	Symbol	Min.	Typ.	Max.	Unit	Notes
Operating Wavelength	λ_c	840	850	860	nm	
Sensitivity (OMA)	SEN			-9.7	dBm	PRBS 2 ⁷ -1 BER \leq 10E-12, ER=9dB
Saturation Optical Power	SAT	0			dBm	
Loss of Signal De-Assert Level	LOSD			-11	dBm	
Loss of Signal Assert Level	LOSA	-22			dBm	
Loss of Signal Hysteresis		0.5			dBm	

RECEIVER ELECTRICAL CHARACTERISTICS

Parameter	Symbol	Min.	Typ.	Max.	Unit	Notes
Data Output Differential Swing		200		1200	mV	CML output, AC coupled
Loss of Signal - Low		0		0.4	V	
Loss of Signal - High		2.4		V _{cc}	V	

PIN DESCRIPTION			
PIN	Name	Description	Notes
1	V _{EE}	Transceiver Ground	
2	TX_Fault	Transmitter Fault Indication	
3	TX_Disable1	Transmitter Disable of channel1	Low: transmitter on; High: transmitter off
4	SDA	SDA	The data line of two wire serial interface
5	SCL	SCL	The clock line of two wire serial interface
6	TD-2	Inv. Transmit Data In of channel2	AC-coupled, CML
7	TD+2	Transmit Data In of channel2	AC-coupled, CML
8	LOS1	Loss of signal for channel1	
9	RD+2	Received Data Out of channel2	AC-coupled, CML
10	RD-2	Inv. Received Data Out of channel2	AC-coupled, CML
11	V _{EE}	Transceiver Ground	
12	RD-1	Inv. Received Data Out of channel1	AC-coupled, CML
13	RD+1	Received Data Out of channel1	AC-coupled, CML
14	LOS2	Loss of signal for channel2	
15	V _{CC} R	Receiver Power	
16	V _{CC} T	Transmitter Power	
17	TX_Disable2	Transmitter Disable of channe2	Low: transmitter on; High: transmitter off
18	TD+1	Transmit Data In of channel1	AC-coupled, CML
19	TD-1	Inv. Transmit Data In of channel1	AC-coupled, CML
20	V _{EE}	Transceiver Ground	

PIN OUT DRAWING (TOP VIEW)

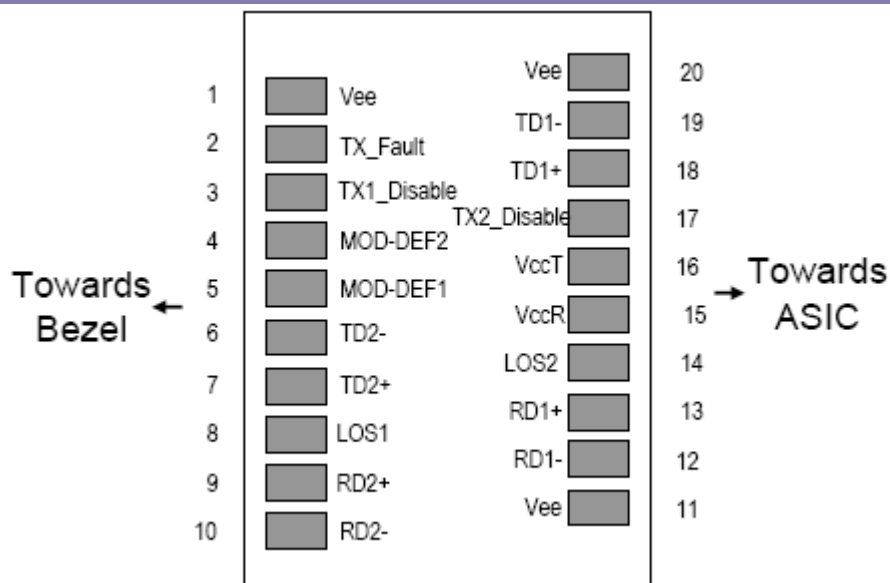

Figure 1 Pin Out Drawing

TYPICAL INTERFACE CIRCUIT

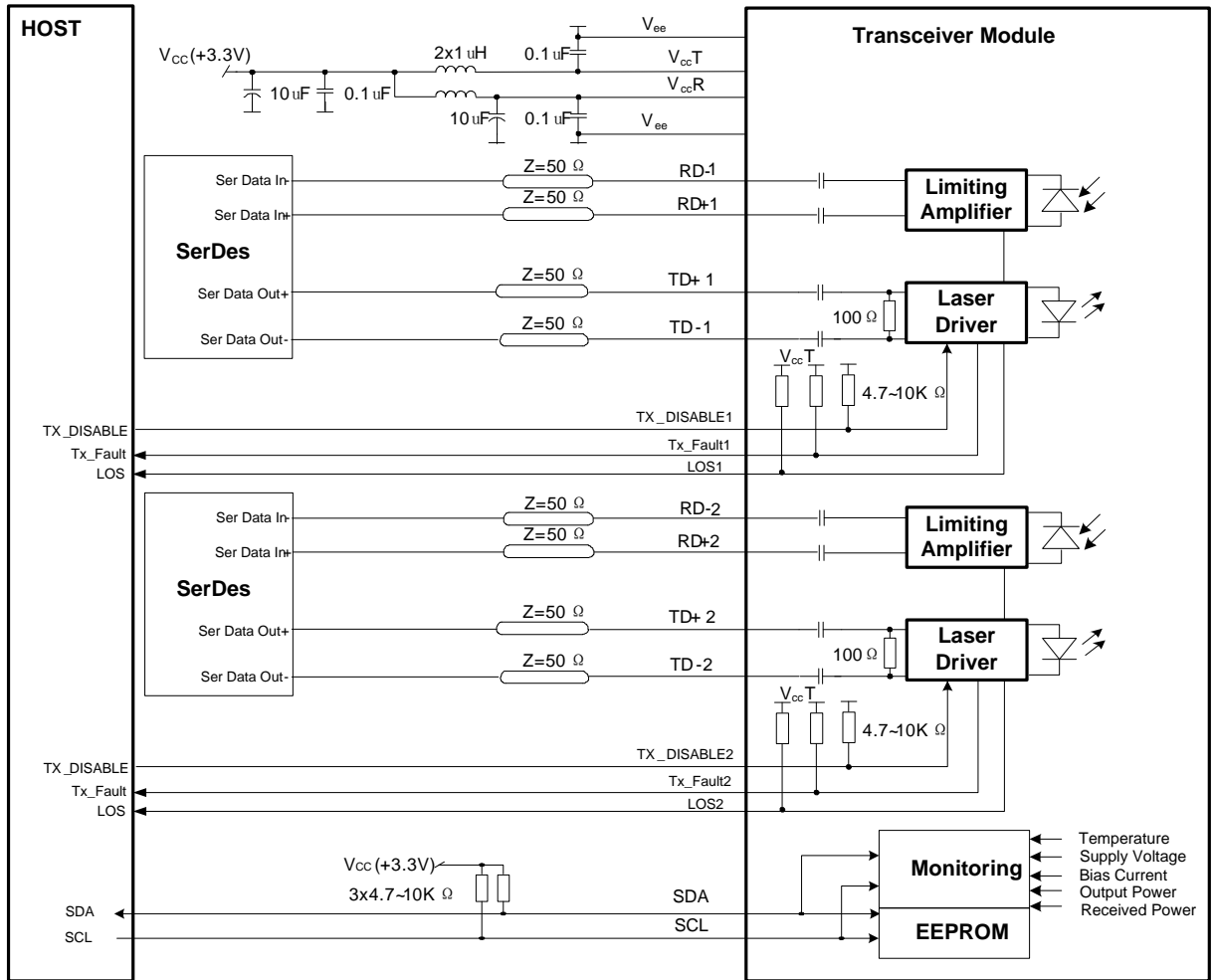

Figure 2 Typical Interface Circuit

SFP RECOMMENDED HOST BOARD POWER SUPPLY FILTERING NETWORK

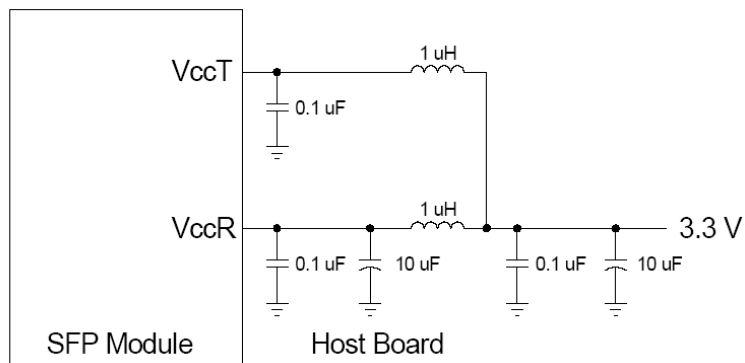
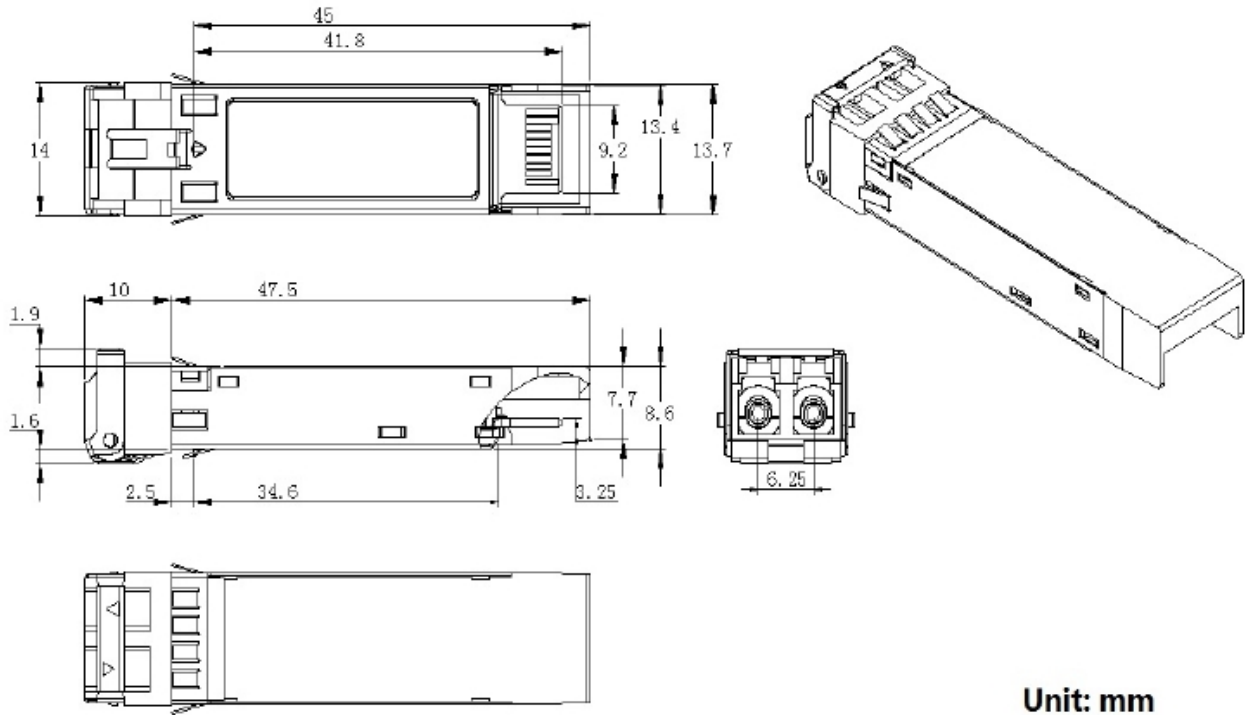

Figure 3 SFP Recommended Host Board Power Supply Filtering Network

PACKAGE OUTLINE



Unit: mm

Figure 4 Package Outline

EEPROM INFORMATION

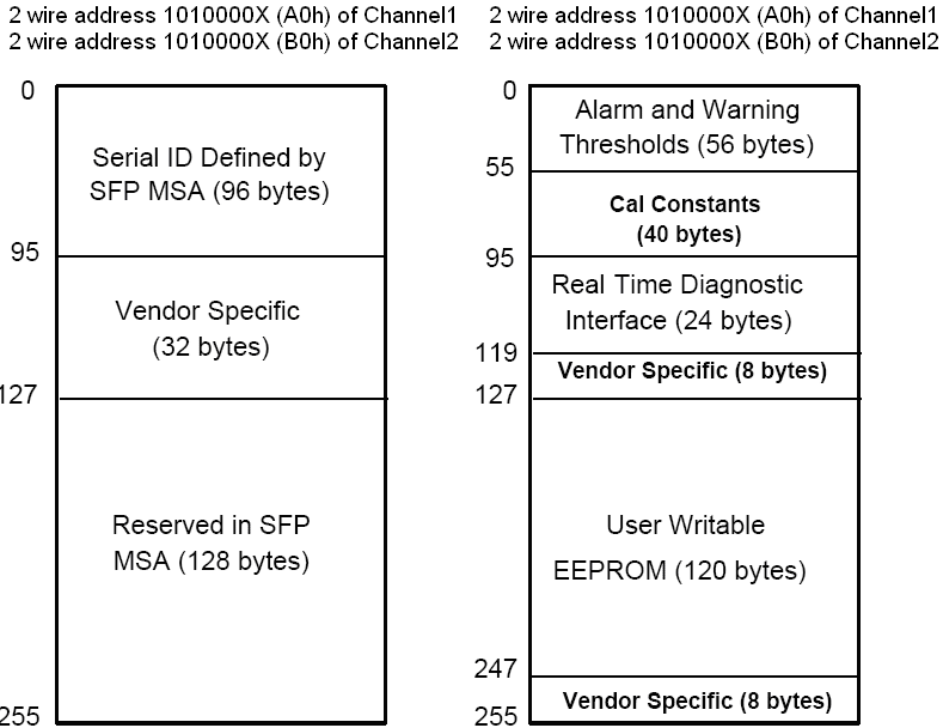

Figure 5 EEPROM Memory Map Specific Data Field Descriptions

DIGITAL DIAGNOSTIC MONITORING INTERFACE

Parameter	Range	Accuracy	Calibration	NOTES
Temperature	0 to 70°C	±3°C	Internal	LSB: 1/256C
Voltage	2.97 to 3.63V	±3%	Internal	LSB: 0.1mV
Bias Current	0 to 100mA	±10%	Internal	LSB: 2uA
TX Power	-7 to 0dBm	±3dB	Internal	LSB: 0.1uW
RX Power	-9 to -0dBm	±3dB	Internal	LSB: 0.1uW

WARNINGS

- Handling Precautions: This device is susceptible to damage as a result of electrostatic discharge (ESD). A static free environment is highly recommended. Follow guidelines according to proper ESD procedures.
- Laser Safety: Radiation emitted by laser devices can be dangerous to human eyes. Avoid eye exposure to direct or indirect radiation.