

FEATURES

- Single fiber bi-directional data links up to 2.5G application
- 1490nm DFB laser transmitter and 1310nm PIN-TIA receiver
- SFP package with simplex LC Receptacle connector
- 0 to 70°C operating case temperature for C-temp class, and -40 to 85°C operating case temperature for I-temp class,
- Single 3.3V power supply
- Digital diagnostic monitoring interface
- 20km transmission distance with SMF
- LVPECL compatible data input/output interface
- Low EMI and excellent ESD protection
- Class I laser safety standard IEC-60825 compliant
- RoHS-6 compliance

APPLICATIONS

- SONET/SDH OC-48 2.488 Gbps
- Fibber Channel 2.125 Gbps
- CPRI L3 2.4576 Gbps

STANDARD

- Complies with SFP Multi-Source Agreement (MSA) SFF-8074i
- Complies with SFF 8472 V9.5
- Compatible with IEEE 802.3
- Compliant with FCC 47 CFR Part 15, Class B
- Complies with FDA 21 CFR 1040.10 and 1040.11 except for deviations pursuant to Laser Notice No. 50, dated June 24, 2007

ABSOLUTE MAXIMUM RATING

Parameter	Symbol	Min.	Max.	Unit	Notes
Storage Ambient Temperature	T _{STG}	-40	85	°C	
Operating Case Temperature	T _C	0	70	°C	For C-temp class
	T _C	-40	85	°C	For I-temp class
Operating Humidity	OH	5	95	%	
Power Supply Voltage	V _{CC}	0	4	V	
Receiver Damaged Threshold		+4		dBm	

RECOMMENDED OPERATING CONDITION

Parameter	Symbol	Min.	Typ.	Max.	Unit	Notes
Operating Case Temperature	T _C	0		70	°C	For C-temp class
	T _C	-40		85	°C	For I-temp class
Power Supply Voltage	V _{CC}	3.13	3.3	3.47	V	
Power Supply Current	I _{CC}			300	mA	
Date Rate			OC-48 2.488 CPRI L3 2.4576 FC 2.125		Gbps	
Data Rate Drift		-100		+100	PPM	

TRANSMITTER OPTICAL CHARACTERISTICS

Parameter	Symbol	Min.	Typ.	Max.	Unit	Notes
Optical Center Wavelength	λ _C	1480	1490	1500	nm	
Optical Spectrum Width (-20dB)	Δλ			1	nm	
Side Mode Suppression Ratio	SMSR	30			dB	
Average Launch Optical Power	AOP	-5		0	dBm	Launched into SMF Fiber
Power-OFF Transmitter Optical Power				-45	dBm	
Extinction Ratio	ER	8.2			dB	
Rise/Fall Time (20%~80%)	tr/tf			0.15	ns	PRBS2 ²³ -1@2.488Gbps
Optical Waveform Diagram		Compatible with ITU-T G.957				PRBS2 ²³ -1@2.488Gbps

TRANSMITTER ELECTRICAL CHARACTERISTICS

Parameter	Symbol	Min.	Typ.	Max.	Unit	Notes
Data Input Differential Swing	V _{in}	200		1600	mV	LVPECL input, AC coupled
Input Differential Impedance	Z _{in}	90	100	110	Ω	
Transmitter Disable Control Voltage - Low		0		0.8	V	
Transmitter Disable Control Voltage - High		2.0		V _{CC}	V	
TX Fault indicate voltage - Low		0		0.4	V	
TX Fault indicate voltage - High		2.4		V _{CC}	V	

RECEIVER OPTICAL CHARACTERISTICS

Parameter	Symbol	Min.	Typ.	Max.	Unit	Notes
Operating Wavelength	λ _c	1260	1310	1360	nm	
Sensitivity	SEN			-18	dBm	Measured with PRBS2 ²³ -1 @ 2.488Gbps, ER=8.2dB, BER≤10 ⁻¹⁰
Saturation Optical Power	SAT	0			dBm	
Loss of Signal De-Assert Level	LOSD			-19	dBm	
Loss of Signal Assert Level	LOSA	-45			dBm	
Signal-Detected Hysteresis		0.5			dB	

RECEIVER ELECTRICAL CHARACTERISTICS

Parameter	Symbol	Min.	Typ.	Max.	Unit	Notes
Data Output Differential Swing	V _{out}	300		1200	mV	CML output, AC coupled
Output Differential Impedance	Z _{out}	90	100	110	Ω	
Loss of Signal indicate voltage - Low		0		0.4	V	
Loss of Signal indicate voltage - High		2.4		V _{CC}	V	

PIN DESCRIPTION			
PIN	Name	Description	Notes
1	VeeT	Transmitter Ground	
2	TX Fault	Transmitter Fault Indication	Low: normal; High: abnormal
3	TX Disable	Transmitter Disable	Low: transmitter on; High: transmitter off
4	MOD-DEF2	Module Definition 2	The data line of two wire serial interface
5	MOD-DEF1	Module Definition 1	The clock line of two wire serial interface
6	MOD-DEF0	Module Definition 0	Connected to GND in the transceiver
7	Rate Select	Not Connected	
8	LOS	Loss of Signal	Low: signal detected; High: loss of signal
9	VeeR	Receiver Ground	
10	VeeR	Receiver Ground	
11	VeeR	Receiver Ground	
12	RD-	Inv. Received Data Out	AC-coupled
13	RD+	Received Data Out	AC-coupled
14	VeeR	Receiver Ground	
15	VccR	Receiver Power	
16	VccT	Transmitter Power	
17	VeeT	Transmitter Ground	
18	TD+	Transmit Data In	AC-coupled
19	TD-	Inv. Transmit Data In	AC-coupled
20	VeeT	Transmitter Ground	

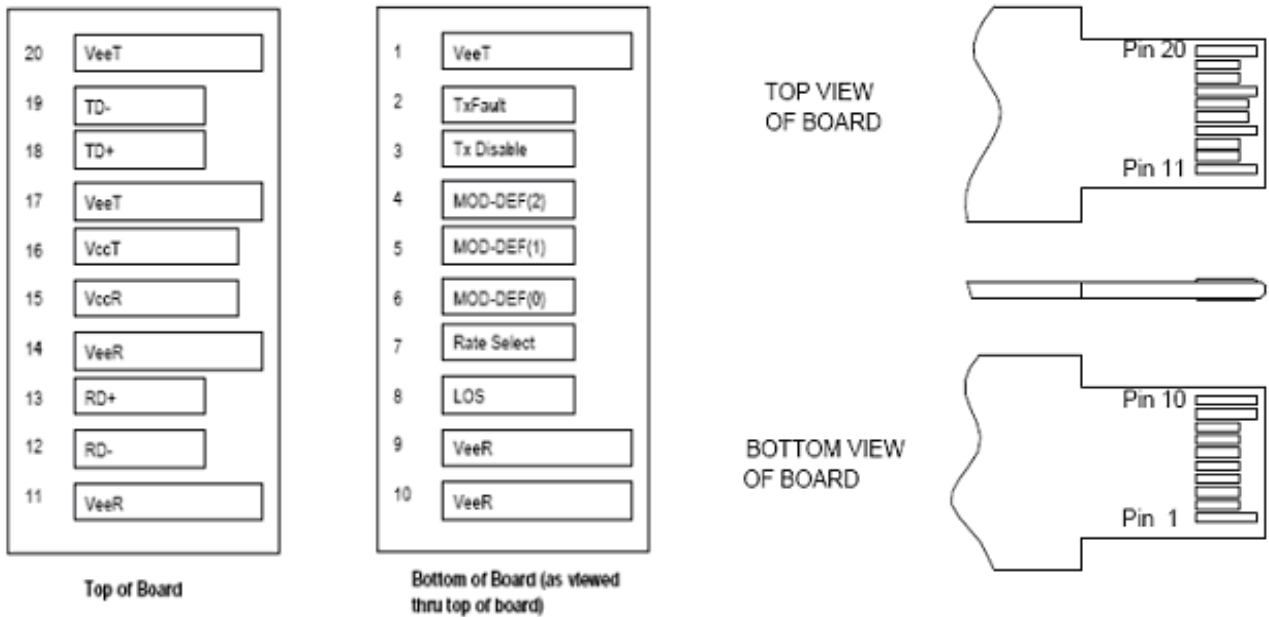

Figure 1 Pin Out Drawing

TYPICAL INTERFACE CIRCUIT

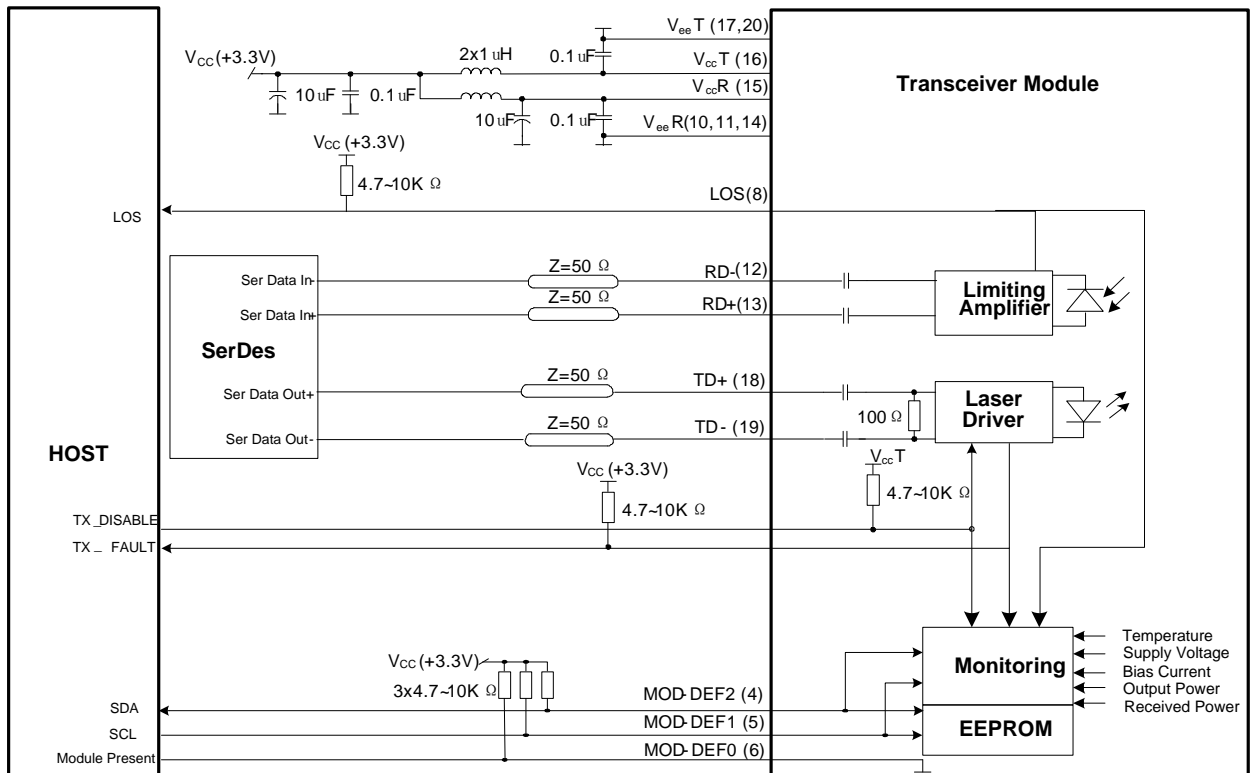
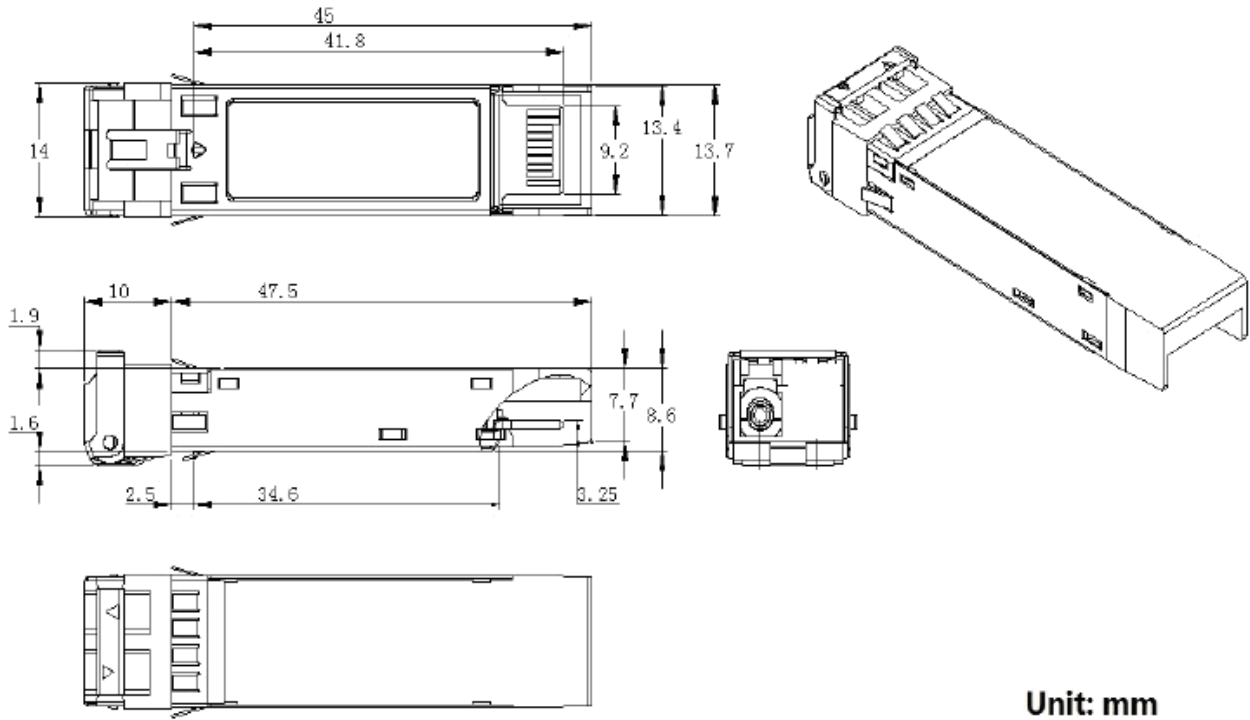

Figure 2 Typical Interface Circuit

PACKAGE OUTLINE



Unit: mm

Figure 3 Package Outline

EEPROM INFORMATION

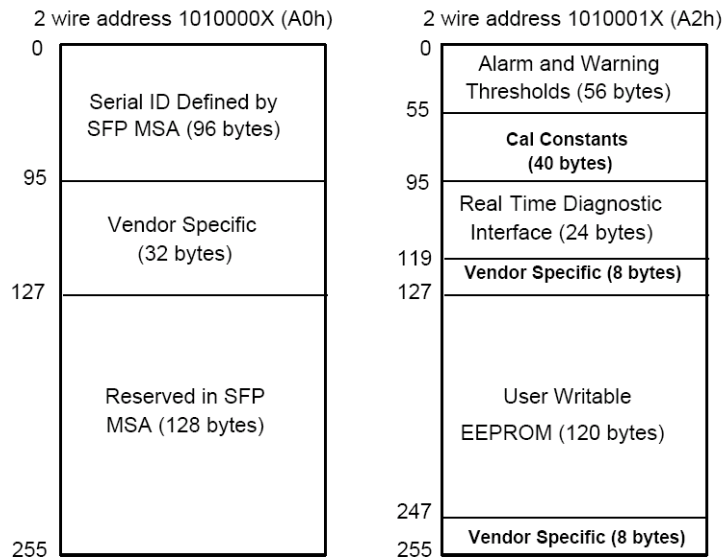

Figure 4 EEPROM Memory Map Specific Data Field Descriptions

DIGITAL DIAGNOSTIC MONITORING INTERFACE

Parameter	Range	Accuracy	Calibration	NOTES
Temperature	-40 to 85°C	±3°C	Internal	LSB: 1/256C
Voltage	3.0 to 3.6V	±3%	Internal	LSB: 0.1mV
Bias Current	0 to 100mA	±10%	Internal	LSB: 2uA
TX Power	-6 to +1dBm	±3dB	Internal	LSB: 0.1uW
RX Power	-19 to +1dBm	±3dB	Internal	LSB: 0.1uW

Order Information

Part Number	Bit Rate (Mbps)	Distance (km)	Wavelength (nm)	Package	TX Power	RX Sensitivity	Monior
HOLS-P2432-LD-CD	2500	20	1490/1310	LC	-5 ~ 0	-18	DDM
HOLS-P2432-LD-ID	2500	20	1490/1310	LC	-5 ~ 0	-18	DDM

WARNINGS

- Handling Precautions: This device is susceptible to damage as a result of electrostatic discharge (ESD). A static free environment is highly recommended. Follow guidelines according to proper ESD procedures.
- Laser Safety: Radiation emitted by laser devices can be dangerous to human eyes. Avoid eye exposure to direct or indirect radiation.