

**Features:**

- Compliant with SFP MSA standard
- 3.3V DC power supply
- TX 1550nm DFB/RX 1310nm PIN-TIA, 2500Mbps, 10Km
- Difference LVPECL inputs and outputs
- Bi Direction LC connector
- Compliant with SFF-8472
- Hot Pluggable
- ROHS compliant

**Application:**

- Gigabit Ethernet data link
- Data storage networks
- Other optical links
- Optical access network



**Ordering Information**

Part Number	Bit Rate (Mbps)	Distance (km)	Wavelength ( nm )	Package	TX Power (dBm)	RX Sensitivity (dBm)	Monitor
HOLS-P2351-LN-CD	2500	10	1310/1550	LC	-3 ~ -9	-18	No DDM
HOLS-P2351-LD-CD	2500	10	1310/1550	LC	-3 ~ -9	-18	DDM

**Description**

Honlus 2500Mbps single-mode BiDi LC SFP is a high performance and cost effective transceiver. It is designed to meet Gigabit Ethernet application. The transceiver consists of bi-direction LC connector with TX in 1550nm DFB laser diode (LD) with monitor photo detector (MPD) in eye safety and RX in InGaAs PIN-TIA with 4PIN/5PIN structure. The output of the PD drives the post-amplification, quantizing, and optical signal detection circuits. The receiver is built in the LOS monitoring function. For further information, please see SFP MSA and SFF-8472 standard.

### Block Diagram

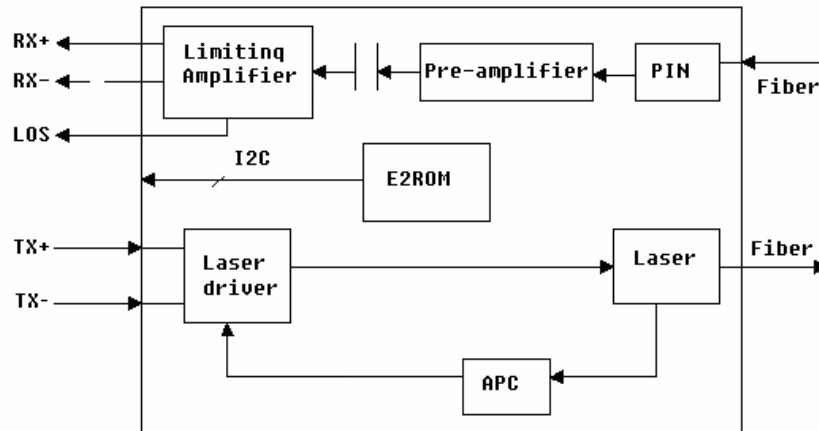

### PECL Logic Level

Logic State	Unit	Min	Typ	Max
Low	V	VCC-1.84	-	VCC-1.60
High	V	VCC-1.10	-	VCC-0.90

### TTL Logic Level

Logic State	Unit	Min	Typ	Max
Low	V	0	-	0.8
High	V	2.4	-	VCC

### Transceiver Pin Locations

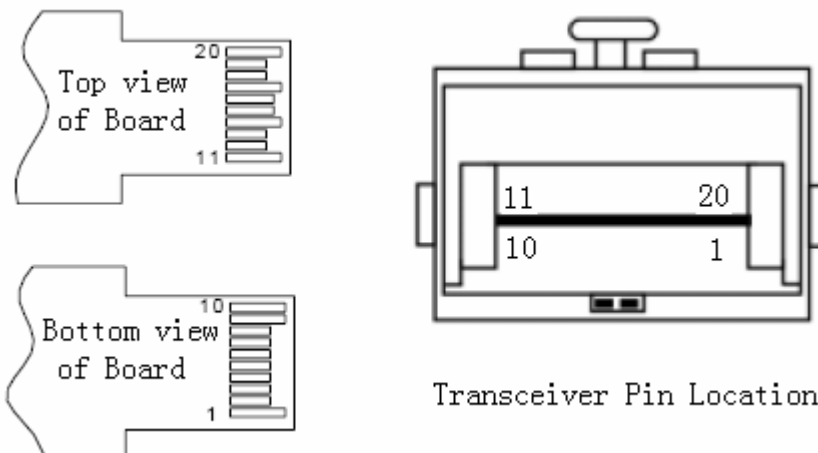

### Pin Descriptions

Pin	Name	Description	Plug Sequence	Note
1	VEET	Transmitter Ground	1	
2	TX Fault	Transmitter Fault Indication	3	1
3	TX Disable	Transmitter Disable	3	2
4	MOD-DEF2	Module Definition 2	3	3
5	MOD-DEF1	Module Definition 1	3	3
6	MOD-DEF0	Module Definition 0	3	3
7	Rate Select	Not Connected	3	
8	LOS	Loss of Signal	3	4
9	VeeR	Receiver Ground	1	
10	VeeR	Receiver Ground	1	
11	VeeR	Receiver Ground	1	
12	RD-	Inverse Received Data Out	3	5
13	RD+	Received Data Out	3	5
14	VeeR	Receiver Ground	1	
15	VccR	Receiver Power	2	
16	VccT	Transmitter Power	2	
17	VeeT	Transmitter Ground	1	
18	TD+	Transmit Data In	3	6
19	TD-	Inverse Transmit Data In	3	6
20	VeeT	Transmitter Ground	1	

Note:

1. 1, TX Fault is an open collector output, which should be pulled up with a 4.7k~10kΩ resistor on the host board to a voltage between 2.0V and Vcc+0.3V. Logic 0 indicates normal operation; logic 1 indicates a laser fault of some kind. In the low state, the output will be pulled to less than 0.8V.
2. TX Disable is an input that is used to shut down the transmitter optical output. It is pulled up within the module with a 4.7k~10kΩ resistor. Its states are:
  - Low (0~0.8V): Transmitter on (>0.8V, <2.0V): Undefined
  - High (2.0~3.465V): Transmitter Disabled
  - Open: Transmitter Disable

3. MOD-DEF 0, 1, 2 are the module definition pins. They should be pulled up with a 4.7k~10kΩ resistor on the host board. The pull-up voltage shall be VccT or VccR.
  - MOD-DEF 0 is grounded by the module to indicate that the module is present
  - MOD-DEF 1 is the clock line of two wire serial interface for serial ID
  - MOD-DEF 2 is the data line of two wire serial interface for serial ID
4. LOS is an open collector output, which should be pulled up with a 4.7k~10kΩ resistor on the host board to a voltage between 2.0V and Vcc+0.3V. Logic 0 indicates normal operation; logic 1 indicates loss of signal. In the low state, the output will be pulled to less than 0.8V.
5. These are the differential receiver outputs. They are AC-coupled 100Ω differential lines which should be terminated with 100Ω (differential) at the user SERDES.
6. These are the differential transmitter inputs. They are AC-coupled, differential lines with 100Ω differential termination inside the module.

### Absolute Maximum Ratings

Parameter	Symbol	Min	Max	Unit
Storage Temperature	T <sub>S</sub>	-40	85	°C
Operating Temperature	T <sub>o</sub>	-0	70	°C
Storage Relative Humidity	RH <sub>S</sub>	-	95	%
Power Supply	VCC	-	5.5	V
Lead Solder Temperature	T <sub>SLD</sub>	-	260	°C
Lead Solder Duration	t <sub>SLD</sub>	-	10	s
Voltage on any input/output	V <sub>IO</sub>	0	VCC	V

### Performance Specification

Transmitter Characteristics						
Parameter	Symbol	min	Typ	Max	Unit	Note
Supply Voltage	VCC	3.15	3.3	3.45	V	-
Operation Current	I <sub>CC</sub>	-	-	130	mA	-
Differential Input Voltage	V <sub>IN</sub>	400	-	1600	mV	-
Data Rate	Rate	-	2500	-	Mbps	-
Optical Output Power	P <sub>o</sub>	-9	-	-3	dBm	-

Extinction Ratio	ER	8.2	-	-	dB	-
Central Wavelength		1480	1550	1580	nm	-
Output Spectrum Width	$\Delta\lambda$	-	-	1	nm	RMS
Optical Rise Time	$T_r$	-	-	0.26	ns	20%~80%
Optical Fall Time	$T_f$	-	-	0.26	ns	20%~80%
Eye Diagram	Compliant IEEE802.3z					

Receiver Characteristics						
Parameter	Symbol	min	Typ	Max	Unit	Note
Supply Voltage	VCC	3.14	3.3	3.47	V	-
Operation Current	I <sub>OC</sub>	-	-	120	mA	-
Differential Output Voltage	V <sub>OUT</sub>	400	-	2000	mV	1
Data Rate	Rate	-	2500	-	Mbps	-
Sensitivity	S	-	-	-18	dBm	2
Optical Input Overload	P <sub>OL</sub>	-3	-	-	dBm	-
Central Wavelength		1260	1310	1360	nm	-
SD (Signal Detected)	Optical Decreased	-35	-	-	dBm	-
	Optical Increased		-	-18	dBm	-
SD Hysteresis	P <sub>H</sub>	0.5	-	5	dB	-

Note1: Internally AC coupled.

Note2: Average received power where the BER =  $10^{-12}$ , measured with a  $2^{23}-1$  NRZ test pattern..

### Power Supply

The Transceiver includes internal circuit components to filter power supply noise. Under some conditions of EMI and power supply noise, external power supply filtering may be necessary. If receiver sensitivity is found to be degraded by power supply noise, the filter network illustrated in the following figure may be used to improve performance. The values of the filter components are general recommendations and may be changed to suit a particular system environment. Shielded inductors are recommended.

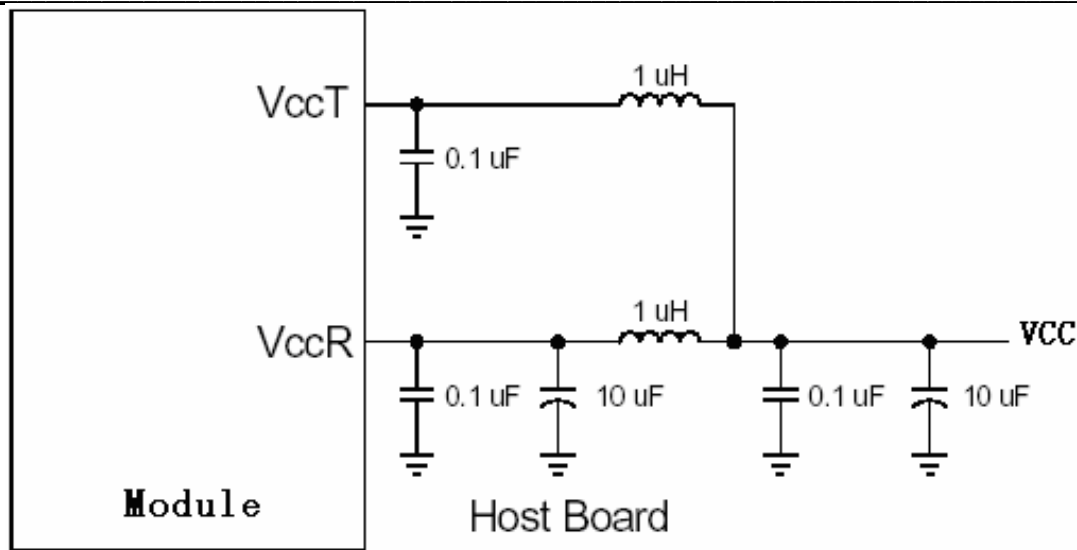

**Recommended Application Circuits**

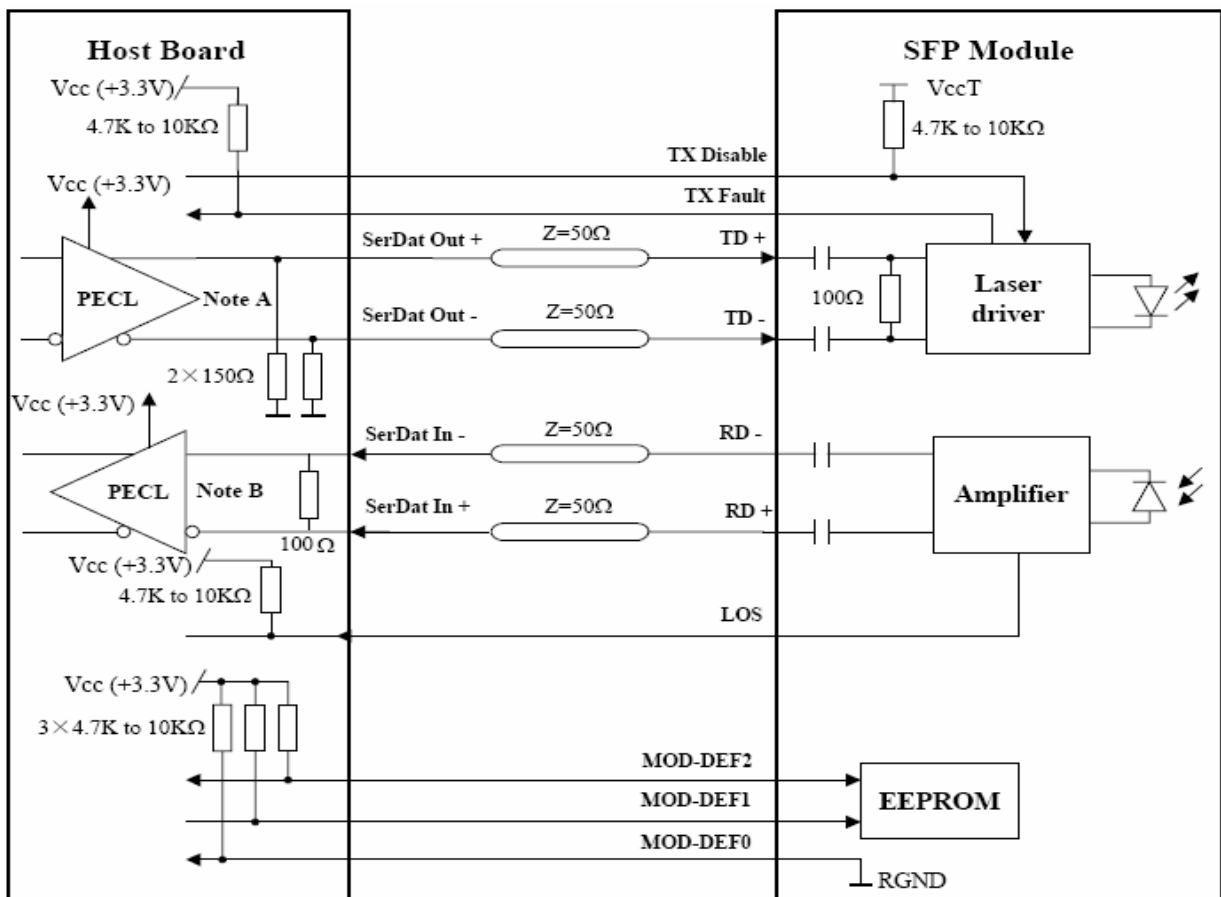

**Recommended Front Panel Layout Opening for LC**

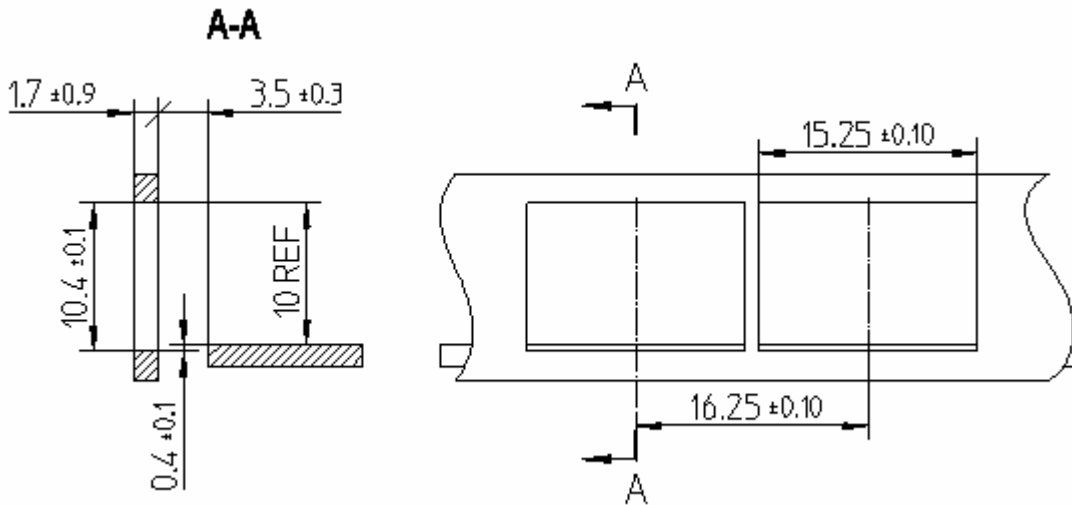

**Outline Specification**

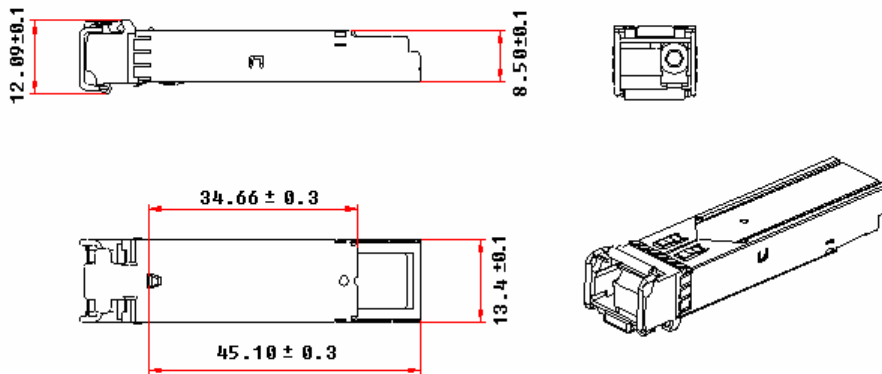

**Ordering Information**

Part Number	Wavelength	Monitor	Devices Type	Temperature
HOLS-P2531-LN-CD	1550nm/1310nm	No DDM	DFB/PIN-TIA	-0°C~70°C
HOLS-P2531-LD-CD	1550nm/1310nm	DDM	DFB/PIN-TIA	-0°C~70°C