

FEATURES

- Single fiber bi-directional data links up to 1250Mbps application
- 1310nm DFB laser transmitter and 1550nm PIN-TIA receiver
- SFP package with simplex LC Receptacle connector
- 0 to 70°C operating case temperature for C-temp
- Single 3.3V power supply
- Digital diagnostic monitoring interface
- 80km transmission distance with SMF
- LVPECL compatible data input/output interface
- Low EMI and excellent ESD protection
- Class I laser safety standard IEC-60825 compliant
- RoHS-6 compliance

APPLICATIONS

- Gigabit Ethernet 1250Mbps
- Fibber Channel 1062.5Mbps
- CPRI L2 1228.8Mbps

STANDARD

- Complies with SFP Multi-Source Agreement (MSA) SFF-8074i
- Complies with SFF 8472 V9.5
- Compatible with IEEE 802.3
- Compliant with FCC 47 CFR Part 15, Class B
- Complies with FDA 21 CFR 1040.10 and 1040.11 except for deviations pursuant to Laser Notice No. 50, dated June 24, 2007

ABSOLUTE MAXIMUM RATING						
Parameter	Symbol	Min.	Max.	Unit	Notes	
Storage Ambient Temperature	T _{STG}	-40	85	°C		
Operating Case Temperature	T _c	0	70	°C		
Operating Humidity	OH	5	95	%		
Power Supply Voltage	V _{CC}	0	4	V		
Receiver Damaged Threshold		0		dBm		

RECOMMENDED OPERATING CONDITION						
Parameter	Symbol	Min.	Typ.	Max.	Unit	Notes
Operating Case Temperature	T _c	0		70	°C	
Power Supply Voltage	V _{CC}	3.13	3.3	3.47	V	
Power Supply Current	I _{CC}			300	mA	
Date Rate			FC 1.0625 CPRI-L2 1.2288 GbE 1.25		Gbps	
Data Rate Drift		-100		+100	PPM	

TRANSMITTER OPTICAL CHARACTERISTICS						
Parameter	Symbol	Min.	Typ.	Max.	Unit	Notes
Optical Center Wavelength	λ _c	1290	1310	1330	nm	
Optical Spectrum Width (-20dB)	Δλ			1	nm	
Side Mode Suppression Ratio	SMSR	30			dB	
Average Launch Optical Power	AOP	0		+5	dBm	Launched into SMF Fiber
Power-OFF Transmitter Optical Power				-45	dBm	
Extinction Ratio	ER	6	9		dB	
Rise/Fall Time (20%~80%)	tr/tf			0.26	ns	PRBS2 ⁷ -1 @1.25Gbps
Optical Waveform Diagram			IEEE 802.3z			PRBS2 ⁷ -1 @1.25Gbps

TRANSMITTER ELECTRICAL CHARACTERISTICS

Parameter	Symbol	Min.	Typ.	Max.	Unit	Notes
Data Input Differential Swing	V _{in}	200		1600	mV	LVPECL input, AC coupled
Input Differential Impedance	Z _{in}	90	100	110	Ω	
Transmitter Disable Control Voltage - Low		0		0.8	V	
Transmitter Disable Control Voltage - High		2.0		V _{CC}	V	
TX Fault indicate voltage - Low		0		0.4	V	
TX Fault indicate voltage - High		2.4		V _{CC}	V	

RECEIVER OPTICAL CHARACTERISTICS

Parameter	Symbol	Min.	Typ.	Max.	Unit	Notes
Operating Wavelength	λ _c	1550	1550	1580	nm	
Sensitivity	SEN			-25	dBm	Measured with PRBS 2 ⁷ -1 @ .
Saturation Optical Power	SAT	-3			dBm	1.25Gpbs, ER=9dB, BER≤10 ⁻¹²
Loss of Signal De-Assert Level	LOSD			-26	dBm	
Loss of Signal Assert Level	LOSA	-45			dBm	
Loss of Signal Hysteresis		0.5			dB	

RECEIVER ELECTRICAL CHARACTERISTICS

Parameter	Symbol	Min.	Typ.	Max.	Unit	Notes
Data Output Differential Swing	V _{out}	200		1600	mV	LVPECL output, AC coupled
Output Differential Impedance	Z _{out}	90	100	110	Ω	
Loss of Signal indicate voltage - Low		0		0.4	V	
Loss of Signal indicate voltage - High		2.4		V _{CC}	V	

PIN DESCRIPTION			
PIN	Name	Description	Notes
1	VeeT	Transmitter Ground	
2	TX Fault	Transmitter Fault Indication	Low: normal; High: abnormal
3	TX Disable	Transmitter Disable	Low: transmitter on; High: transmitter off
4	MOD-DEF2	Module Definition 2	The data line of two wire serial interface
5	MOD-DEF1	Module Definition 1	The clock line of two wire serial interface
6	MOD-DEF0	Module Definition 0	Connected to GND in the transceiver
7	Rate Select	Not Connected	
8	LOS	Loss of Signal	Low: signal detected; High: loss of signal
9	VeeR	Receiver Ground	
10	VeeR	Receiver Ground	
11	VeeR	Receiver Ground	
12	RD-	Inv. Received Data Out	AC-coupled
13	RD+	Received Data Out	AC-coupled
14	VeeR	Receiver Ground	
15	VccR	Receiver Power	
16	VccT	Transmitter Power	
17	VeeT	Transmitter Ground	
18	TD+	Transmit Data In	AC-coupled
19	TD-	Inv. Transmit Data In	AC-coupled
20	VeeT	Transmitter Ground	

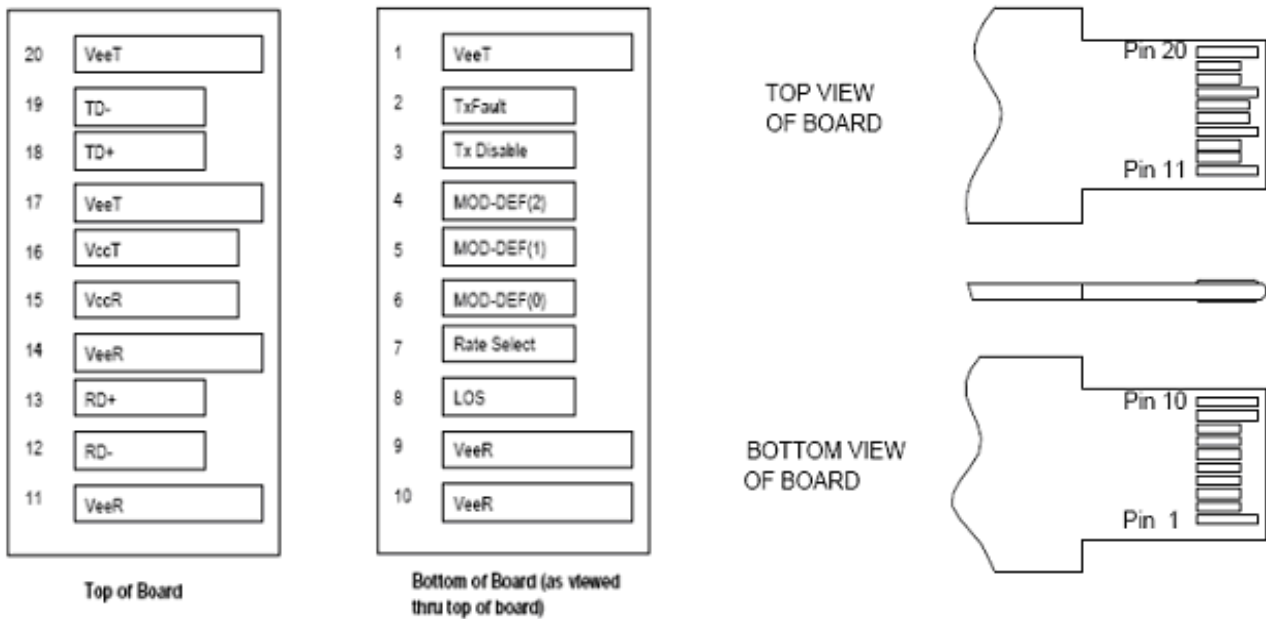

Figure 1 Pin Out Drawing

TYPICAL INTERFACE CIRCUIT

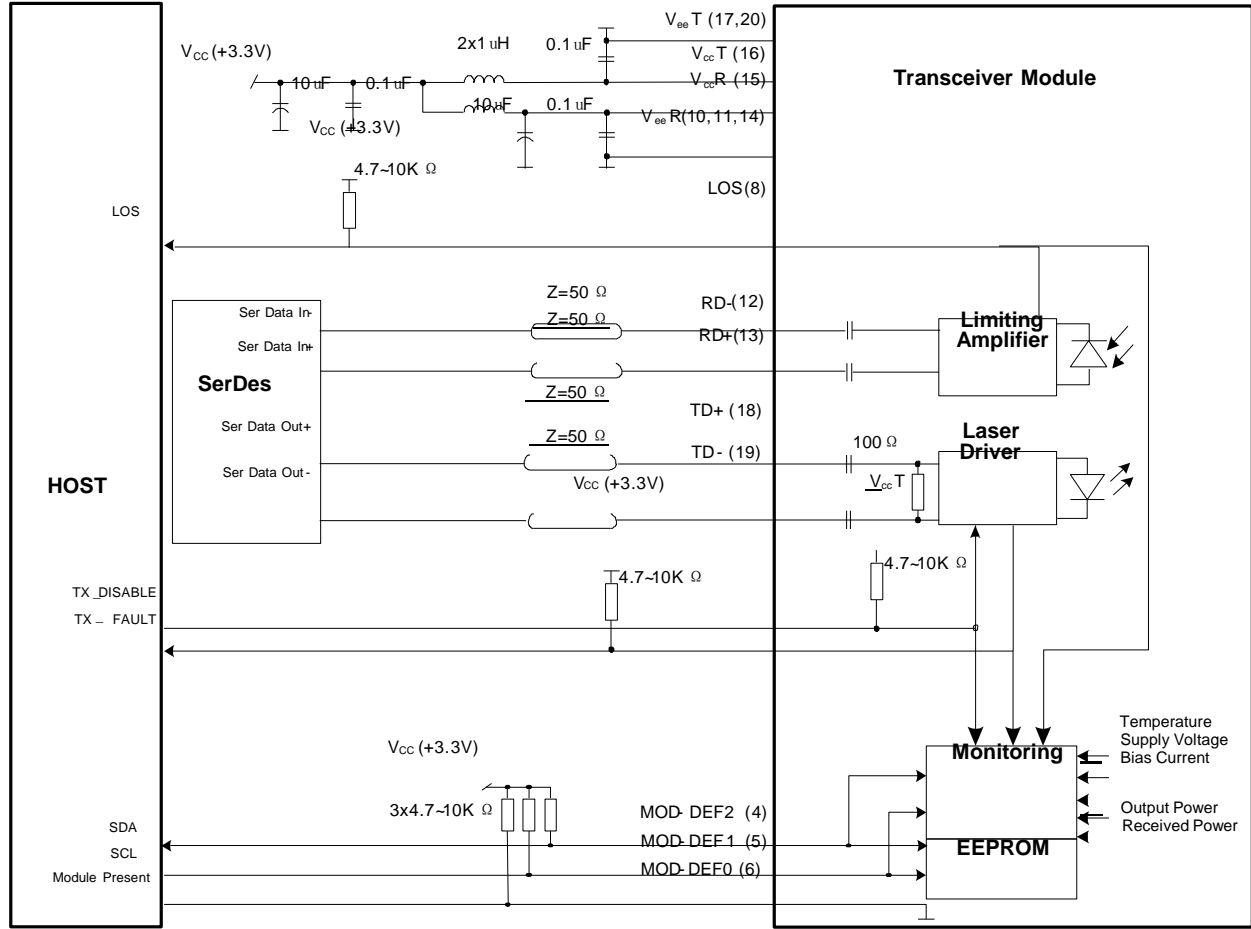

Figure 2 Typical Interface Circuit

PACKAGE OUTLINE

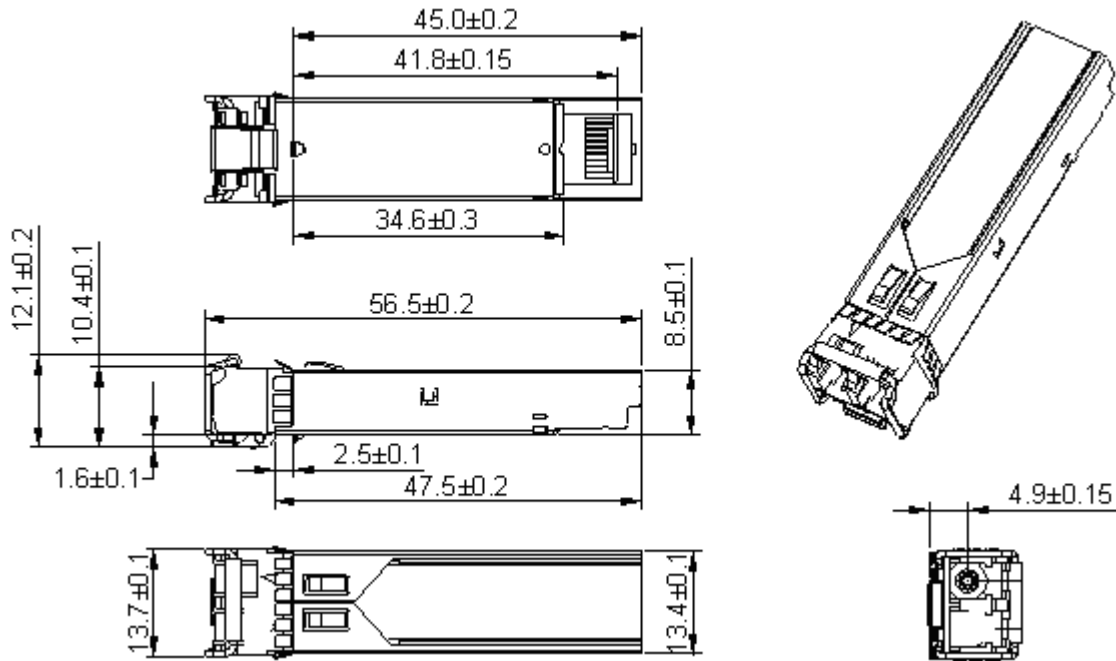

Figure 3 Package Outline

EEPROM INFORMATION

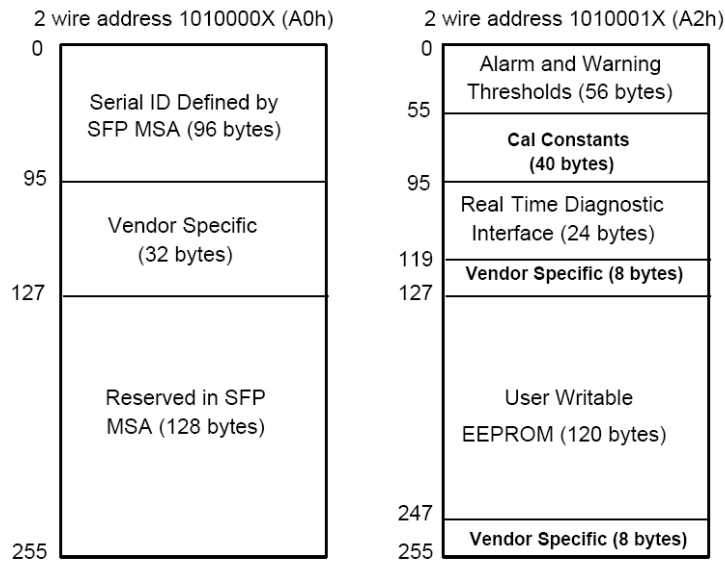

Figure 4 EEPROM Memory Map Specific Data Field Descriptions

DIGITAL DIAGNOSTIC MONITORING INTERFACE

Parameter	Range	Accuracy	Calibration	NOTES
Temperature	-40 to 85°C	±5°C	Internal	LSB: 1/256C
Voltage	3.0 to 3.6V	±3%	Internal	LSB: 0.1mV
Bias Current	0 to 100mA	±10%	Internal	LSB: 2uA
TX Power	-1 to +6dBm	±3dB	Internal	LSB: 0.1uW
RX Power	-26 to -2dBm	±3dB	Internal	LSB: 0.1uW

WARNINGS

- Handling Precautions: This device is susceptible to damage as a result of electrostatic discharge (ESD). A static free environment is highly recommended. Follow guidelines according to proper ESD procedures.
- Laser Safety: Radiation emitted by laser devices can be dangerous to human eyes. Avoid eye exposure to direct or indirect radiation.