10Gbps DWDM XFP Optical Transceiver

HOLS-XPDxx8099-LD-CE

Product Features

- Cooled DWDM EML laser and APD photodiode
- Up to 80km (1600ps/nm dispersion) Transmission Distance
- Supports 9.95Gbps to 11.3Gbps bit rates
- Hot-pluggable XFP MSA with duplex LC connect
- XFI electrical interface
- Built-in digital diagnostic function
- +5V, +3.3V power supply
- Low power consumption <3.5W
- Operating case temperature: -5 to 75 °C
- Excellent EMI performance
- High reliability
- Compatible with RoHS6



Product Applications

- SONET(OC-192)/SDH(STM-64) line card
- 10GBASE-LR Ethernet
- 10G FC
- DWDM Networks

Description

The Honlus HOLS-XPD8099 is a multi-purpose optical transceiver module for 10Gbit/s data transmission applications at DWDM networks. It is compliant with the 10G Small Form-Factor Pluggable (XFP) Multi-Source Agreement (MSA), supporting data-rate from 9.95Gbps to 11.3Gbps, and transmission distance up to 80km. The transceiver module comprises a transmitter with cooled DWDM EML laser and a receiver with an APD photodiode. Transmitter and receiver are separate within a wide temperature range of -5 °C to +75°C and offers optimum heat dissipation and excellent electromagnetic shielding thus enabling high port densities for 10 GbE systems.

Performance Specifications

Absolute Maximum Ratings				
Parameter	Symbol	Min.	Max.	Unit
Storage Temperature range	-	-40	+85	°C
operating Temperature range	-	-5	75	°C
Operating Relative Humidity	RH	-	85	%
Supply Voltage Range @ 5.0V	Vcc5	-0.3	6	V
Supply Voltage Range @ 3.3V	Vcc3	-0.5	3.6	V
Voltage On Open Collector Output	Voco	0	6	V
Voltage On LVTTTL Input	-	-0.5	3.6	V
LVTTTL Input Current	-	-	15	mA
Receiver Damage Thresheld	-	-	-2	dBm

Recommended Operating Conditions						
Parameter	Symbol	Min	Typ	Max	Units	Note
Operating Case Temperature Range		-5	-	75	°C	-
Transceiver total Power Consumption	Ptotal	-	-	3.5	W	-
Power Supply Voltage @ 5.0V	Vcc5	4.75	5.00	5.25	V	-
Power Supply Voltage @ 3.3V	Vcc3	3.135	3.30	3.465	V	-
Supply Current	IVCC 3	-	400	1100	mA	-
Supply Current	IVCC 5	-	80	100	mA	-

Optical Specification						
Transmitter						
Parameter	Symbol	Min	Typ	Max	Units	Note
Data Rate	DR	9.95	-	11.3	Gbps	-
Center Wavelength (BOL)	λ	$\lambda-0.025$	λ	$\lambda+0.025$	nm	1
Center Wavelength (EOL)	λ	$\lambda-0.1$	λ	$\lambda+0.1$	nm	1
Center Wavelength Spacing	λ	-	100	-	GHz	1
Laser off power	Poff	-	-	-30	dBm	-
Optical output Power	Pout	0	-	4	dBm	-
Extinction Ratio	ER	9	-	-	dB	-
Side Mode Suppression Ratio	SMSR	30	-	-	dB	-
Dispertion Tolerance	DT	-200	-	1600	Ps/nm	
Spectral Width(-20dB)	DI20	-	0.1	0.3	nm	-
Jitter Generation	Tjp-p	-	-	0.1	UI	-
Dispertion Penalty	DP	-	-	1.2	dB	-
Relative Intensity Noise	RIN	-	-	-130	dB/Hz	-

Optical eye mask	Compliant with ITU-T G691 STM-64	-
------------------	----------------------------------	---

Optical Specification							
Receiver							
Parameter	Symbol	Min	Typ	Max	Units	Note	
Data Rate	DR	9.95	-	11.3	Gbps	-	
Center Wavelength	λ	1250	-	1630	nm		
Receiver Sensitivity	<i>Sens</i>	-	-	-24	dBm	1	
Maximum Input Power	<i>Pmax</i>	-6	-	-	dBm		
Receiver Reflectance	-	-	-	-27	dB		
LOS De-Assert	LOSD	-	-	-32	dBm		
LOS Assert	LOSA	-35	-	-	dBm		
LOS Hysteresis	-	0.5	-	-	dB		

Notes:

1. Measured with a PRBS ³¹ 2⁻¹ test pattern @9.953Gbps BER≤10⁻¹²

Electrical Specification

Transmitter

Parameter	Symbol	Min	Typ	Max	Units	Note
Input Differential Impedance	RIND		100		Ω	
Differential input Voltage Swing	VID	50		700	mV	
Transmit Disable Voltage	VDis	2		VCC3		
Transmit Enable Voltage	VEN	0		0.8		

Electrical Specification

Receiver

Parameter	Symbol	Min	Typ	Max	Units	Note
Differential Output Amplitude	VOSPP	360	-	770	mV	
LOS on	-	Vcc3-0.9	-	Vcc3	V	
LOS off	-	0	-	0.4	V	

PIN Diagram

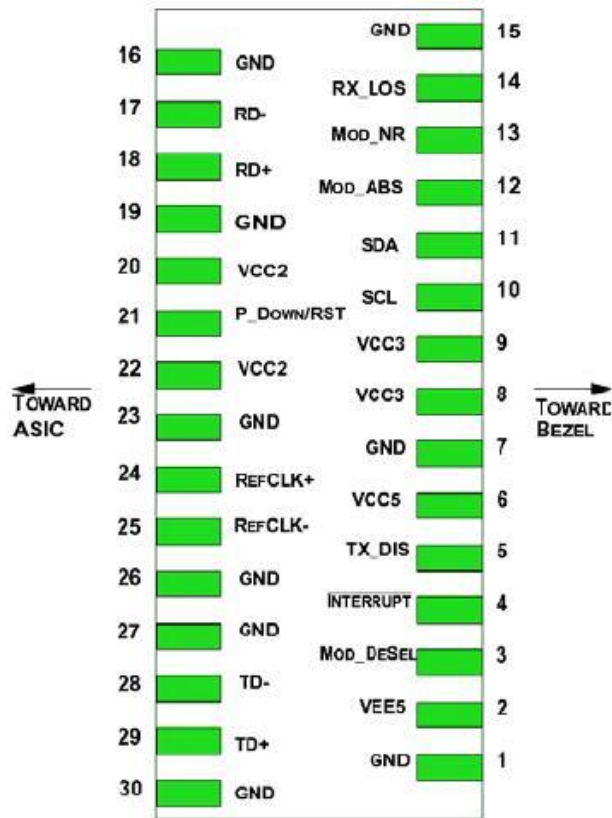

Figure 1

PIN Description

Pin	Logic	Symbol	Name/Description	Ref.
1		GND	Module Ground	1
2		VEE5	Optional –5.2 Power Supply – Not required	
3	LVTTTL-I	Mod-Desel	Module De-select; When held low allows the module to , respond to 2-wire serial interface commands	
4	LVTTTL-O	Interrupt	Interrupt (bar); Indicates presence of an important condition which can be read over the serial 2-wire interface	2
5	LVTTTL-I	TX_DIS	Transmitter Disable; Transmitter laser source turned off	
6		VCC5	+5 Power Supply	
7		GND	Module Ground	1
8		VCC3	+3.3V Power Supply	
9		VCC3	+3.3V Power Supply	
10	LVTTTL-I	SCL	Serial 2-wire interface clock	2
11	LVTTTL- I/O	SDA	Serial 2-wire interface data line	2
12	LVTTTL-O	Mod_Abs	Module Absent; Indicates module is not present. Grounded in the module.	2
13	LVTTTL-O	Mod_NR	Module Not Ready;	2
14	LVTTTL-O	RX_LOS	Receiver Loss of Signal indicator	2
15		GND	Module Ground	1
16		GND	Module Ground	1
17	CML-O	RD-	Receiver inverted data output	
18	CML-O	RD+	Receiver non-inverted data output	
19		GND	Module Ground	1
20		VCC2	+1.8V Power Supply – Not required	
21	LVTTTL-I	P_Down/ RST	Power Down; When high, places the module in the low power stand-by mode and on the falling edge of P_Down initiates a module reset	
			Reset; The falling edge initiates a complete reset of the module including the 2-wire serial interface, equivalent to a power cycle.	
22		VCC2	+1.8V Power Supply – Not required	
23		GND	Module Ground	1
24	PECL-I	RefCLK+	Reference Clock non-inverted input, AC coupled on the host board – Not required	3
25	PECL-I	RefCLK-	Reference Clock inverted input, AC coupled on the host board – Not required	3
26		GND	Module Ground	1
27		GND	Module Ground	1

28	CML-I	TD-	Transmitter inverted data input	
29	CML-I	TD+	Transmitter non-inverted data input	
30		GND	Module Ground	1

Note

1. Module circuit ground is isolated from module chassis ground within the module.
2. Open collector; should be pulled up with 4.7k – 10k ohms on host board to a voltage between 3.15V and 3.6V.
3. A Reference Clock input is not required .

Block Diagram

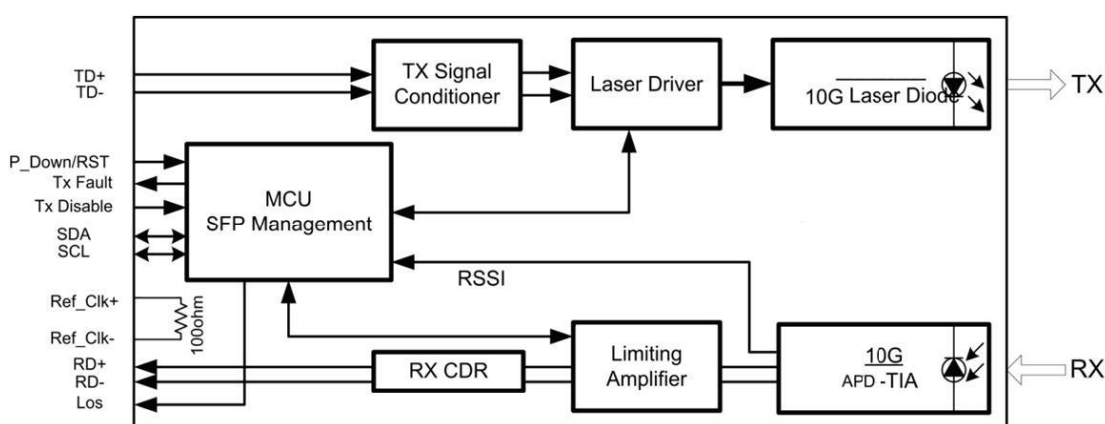

Figure 2

Transmitter Section

The transmitter converts 10Gbit/s serial PECL or CML electrical data into serial optical data compliant with the 10GBASE-LR standard. An open collector compatible Transmit Disable (Tx_Dis) is provided. A logic “1,” or no connection on this pin will disable the laser from transmitting. A logic “0” on this pin provides normal operation. The transmitter has an internal automatic power control loop (APC) to ensure constant optical power output across supply voltage and temperature variations. An open collector compatible Transmit Fault (Tx_Fault) is provided. TX_Fault is a module output contact that when high, indicates that the module transmitter has detected a fault condition related to laser operation or safety. The TX_Fault output contact is an open drain/collector and shall be pulled up to the Vcc_Host in the host with a resistor in the range 4.7-10 kΩ. TX_Disable is a module input contact. When TX_Disable is asserted high or left open, the module transmitter output shall be turned off. This contact shall be pulled up to VccT with a 4.7-10 kΩ resistor.

Receiver Section

The receiver converts 10Gbit/s serial optical data into serial PECL/CML electrical data. An open collector compatible Loss of Signal is provided. Rx_LOS when high indicates an optical signal level below that specified in the relevant standard. The Rx_LOS contact is an open drain/collector

output and shall be pulled up to Vcc_Host in the host with a resistor in the range 4.7-10 k Ω , or with an active termination. Power supply filtering is recommended for both the transmitter and receiver. The Rx_LOS signal is intended as a preliminary indication to the system in which the module is installed that the received signal strength is below the specified range. Such an indication typically points to non-installed cables, broken cables, or a disabled, failing or a powered off transmitter at the far end of the cable.

Manage interface

The transceivers provide serial ID memory contents and diagnostic information about the present operating conditions by the 2-wire serial interface (SCL, SDA). The Module provides diagnostic information about the present operating conditions. The transceiver generates this diagnostic data by digitization of internal analog signals. Alarm/warning threshold data is written during device manufacture. Received power monitoring, transmitted power monitoring, bias current monitoring, supply voltage monitoring and temperature monitoring all are implemented. The digital diagnostic memory map specific data field defines as following.

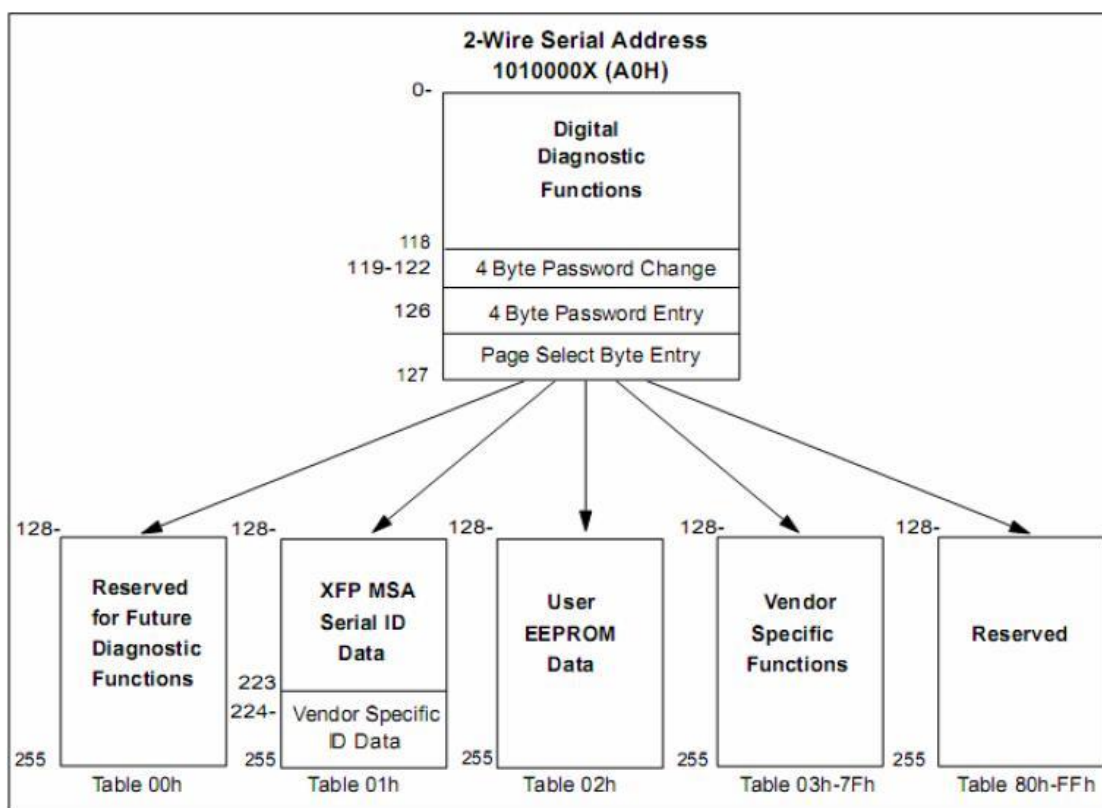

Figure 3

Recommended High-Speed Interface Circuit

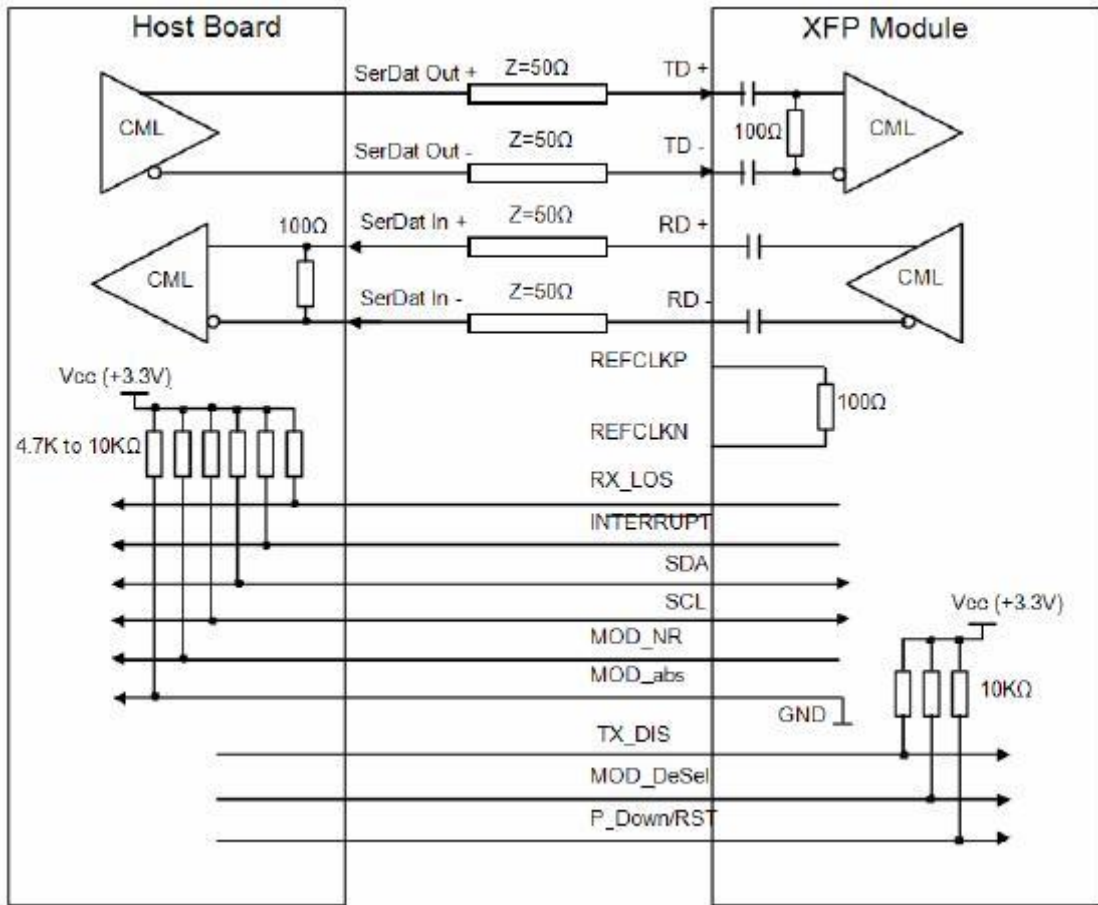
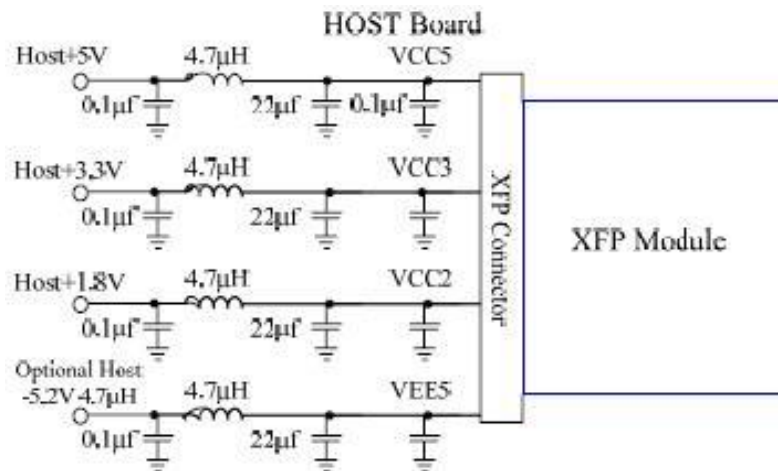
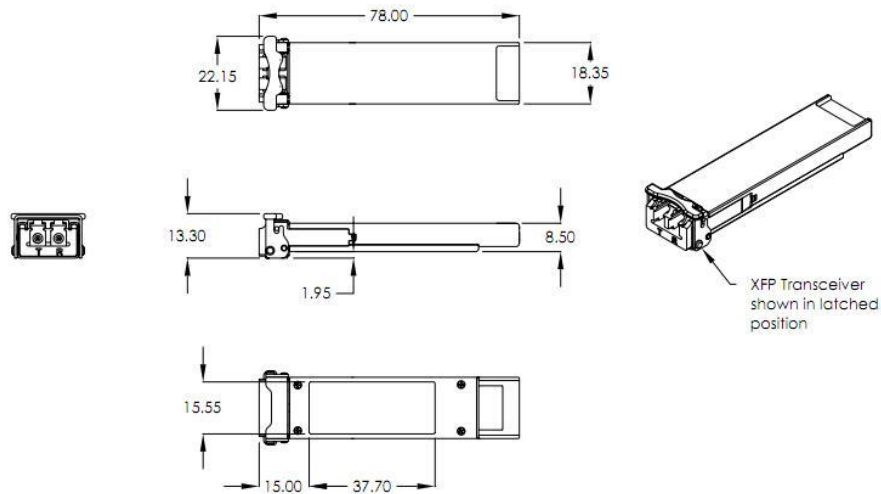

Figure 4

Recommended Host Board Power Supply Circuit



Package Diagram



XFP Transceiver (dimensions are in mm)

Order Information

Part No.	Tx/Rx	Data Rate	Operating Temp	Distance
HOLS-XPDxx8099-LD-CE	EML/APD	9.95G~11.3G	0 to +70°C	80km
HOLS-XPDxx8099-LD-IE	EML/APD	9.95G~11.3G	-40 to +85°C	80km

Note:
 XX is ITU Grid 17-61 as in below table.

ITU Channel Product Code	Frequency(THz)	Wavelength	ITU Channel Product Code	Frequency(THz)	Wavelength
17	191.7	1563.86	40	194.0	1545.32
18	191.8	1563.05	41	194.1	1544.53
19	191.9	1562.23	42	194.2	1543.73
20	192.0	1561.42	43	194.3	1542.94
21	192.1	1560.61	44	194.4	1542.14
22	192.2	1559.79	45	194.5	1541.35
23	192.3	1558.98	46	194.6	1540.56
24	192.4	1558.17	47	194.7	1539.77
25	192.5	1557.36	48	194.8	1538.98

26	192.6	1556.55	49	194.9	1538.19
27	192.7	1555.75	50	195.0	1537.40
28	192.8	1554.94	51	195.1	1536.61
29	192.9	1554.13	52	195.2	1535.82
30	193.0	1553.33	53	195.3	1535.04
31	193.1	1552.52	54	195.4	1534.25
32	193.2	1551.72	55	195.5	1533.47
33	193.3	1550.92	56	195.6	1532.68
34	193.4	1550.12	57	195.7	1531.90
35	193.5	1549.32	58	195.8	1531.12
36	193.6	1548.51	59	195.9	1530.33
37	193.7	1547.72	60	196.0	1529.55
38	193.8	1546.92	61	196.1	1528.77
39	193.9	1546.12			

When the ambient is reaching 85C max as declared, the internal case is hot surface please don't touch.

