

## Features:

- XFP MSA Rev 4.5 compliant
- Support multi-rate from 9.95G to 11.3G
- Up to 40km transmission on SMF
- 1550nm EML and PIN receiver
- XFI high speed electrical interface
- 2-wire interface with integrated Digital Diagnostic monitoring
- XFP MSA package with duplex LC connector
- +5V,+3.3V and +1.8V power supplies
- Power consumption less than 3.5 W
- Operating case temperature: -5~+70°C  
-40~+85°C



## Regulatory Compliance

Table 1 - Regulatory Compliance

Feature	Standard	Performance
Electrostatic Discharge (ESD) to the Electrical Pins	MIL-STD-883E Method 3015.7	Class 1(>500V for XFI pins, >2000V for other pins.)
Electrostatic Discharge (ESD) to the Duplex LC Receptacle	IEC 61000-4-2 GR-1089-CORE	Compatible with standards
Electromagnetic Interference (EMI)	FCC Part 15 Class B EN55022 Class B (CISPR 22B) VCCI Class B	Compatible with standards
Immunity	IEC 61000-4-3	Compatible with standards
Laser Eye Safety	FDA 21CFR 1040.10 and 1040.11 EN60950, EN (IEC) 60825-1,2	Compatible with Class I laser product.
RoHS	2002/95/EC 4.1&4.2 2005/747/EC	Compliant with standards <small>note</small>

**Note:**

In light of item 5 in Annex of 2002/95/EC, "Pb in the glass of cathode ray tubes, electronic

components and fluorescent tubes.” and item 13 in Annex of 2005/747/EC, “Lead and cadmium in optical and filter glass.”, the two exemptions are being concerned for Honlus transceivers, because Honlus transceivers use glass, which may contain Pb, for components such as lenses, windows, isolators, and other electronic components.

## Absolute Maximum Ratings

**Table 2 - Absolute Maximum Ratings**

Parameter	Symbol	Min.	Typical	Max.	Unit	Notes
Storage Temperature	T <sub>s</sub>	-40	-	+85	°C	
Supply Voltage	V <sub>CC5</sub>	-0.5	-	+6.0	V	
	V <sub>CC3</sub>	-0.5	-	+4.0	V	
	V <sub>CC2</sub>	-0.5	-	+2.0	V	
Operating Relative Humidity	RH	-	-	+85	%	

## Recommended Operating Conditions

**Table 3 – Recommended Operating Conditions**

Parameter	Symbol	Min.	Typical	Max.	Unit	Notes
Operating Case Temperature	T <sub>c</sub>	-5	-	+70	°C	
Power Supply Voltage	V <sub>CC5</sub>	4.75	5.0	5.25	V	
	V <sub>CC3</sub>	3.14	3.3	3.46	V	
	V <sub>CC2</sub>	1.71	1.8	1.89	V	
Power Supply Current	I <sub>CC5</sub>	-	-	500	mA	
	I <sub>CC3</sub>	-	-	750	mA	
	I <sub>CC2</sub>	-	-	1000	mA	
Power Dissipation	P <sub>D</sub>	-	-	3.5	W	
Bit Rate	BR	9.95	-	11.3	Gbps	
Transmission Distance	TD	2	-	40,000	m	1

Note 1: Measured with G.652 SMF.

## Optical Characteristics

**Table 4 – Optical Characteristics**

Transmitter
-------------

Honlus Technology (Hongkong) Limited  
 Unit 4 7/F, Bright Way Tower, 33 Mong Kok Road, KL, Hongkong  
 Email: sales@honlus.com  
 Website: www.honlus.com



## 10Gbps 1550nm SM XFP Transceiver 40km HOLS-XP154099-LD-xE

Parameter	Symbol	Min.	Typical	Max.	Unit	Notes
Center Wavelength Range	$\lambda_c$	1530	-	1565	nm	
Average Output Power	$P_{OUT}$	-1	-	2	dBm	1
Average Output Power (Laser Off)	$P_{OUT-OFF}$	-	-	-30	dBm	1
Side Mode Suppression Ratio	SMSR	30	-	-	dB	
Extinction Ratio	ER	8.2	-	-	dB	2
Chromatic Dispersion	CD	-	-	800	ps/nm	
Optical Eye Mask	Compliant with ITU-T G.691-2006					2

Receiver						
Parameter	Symbol	Min.	Typical	Max.	Unit	Notes
Center Wavelength Range	$\lambda_c$	1530	-	1565	nm	
Receiver Sensitivity	$P_{IN-SENS}$	-	-	-16	dBm	3
Receiver Overload	$P_{IN-OL}$	-1	-	-	dBm	3
Receiver Reflectance	Ref	-	-	-27	dB	
Optical Path Penalty	OPP	-	-	2	dB	
LOS Assert	$LOS_A$	-25	-	-	dBm	
LOS Deassert	$LOS_D$	-	-	-17	dBm	
LOS Hysteresis	$LOS_H$	0.5	-	4	dB	

Notes:

1. The optical power is launched into SMF.
2. Measured with a PRBS 2<sub>31</sub>-1 test pattern @9.953Gbps.
3. Measured with a PRBS 2<sub>31</sub>-1 test pattern @9.953Gbps, BER≤10<sup>-12</sup>.

### Electrical Characteristics

Table 5 – Electrical Characteristics

Transmitter						
Parameter	Symbol	Min.	Typical	Max.	Unit	Notes
Differential Data Input Amplitude	$V_{IN,P-P}$	120	-	820	mVpp	
Input Differential Impedance	$Z_{IN}$	85	100	115	$\Omega$	
Tx_Disable, P_Down/RST	$V_{IL}$	-0.3	-	0.8	V	
	$V_{IH}$	2.0	-	$V_{CC}+0.3$	V	
Receiver						
Differential Date Output Amplitude	$V_{OUT,P-P}$	340	-	850	mVpp	

Output Differential Impedance	Z <sub>d</sub>	80	100	120	Ω	
Output Rise Time, 20%~80%	T <sub>R</sub>	24	-	-	ps	
Output Fall Time, 20%~80%	T <sub>F</sub>	24	-	-	ps	
Rx_LOS, Mod_NR, Interrupt	V <sub>OL</sub>	0	-	0.4	V	
	V <sub>OH</sub>	V <sub>CC</sub> -0.5	-	V <sub>CC</sub> +0.3	V	

### Recommended Host Board Power Supply Circuit

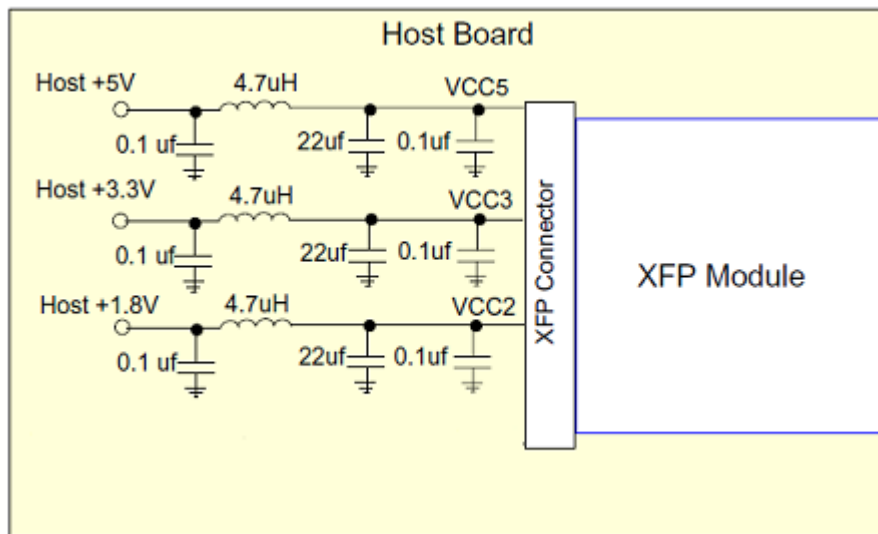

Figure 1, Recommended Host Board Power Supply Circuit

### Recommended Interface Circuit

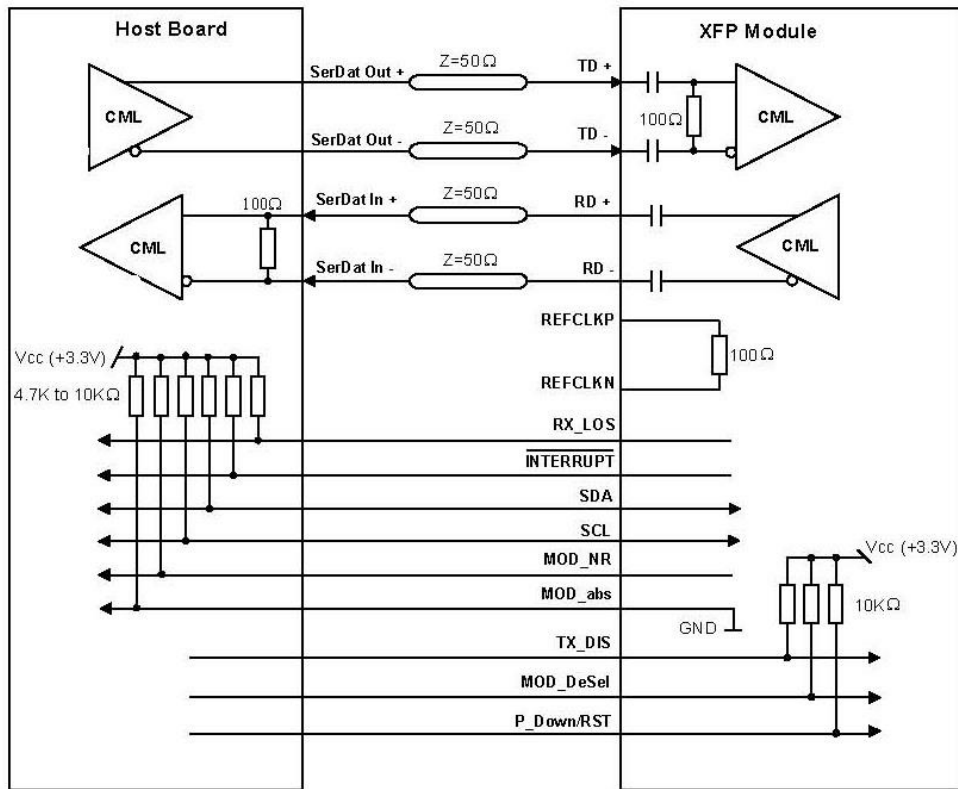

Figure 2, Recommended Interface Circuit

## Pin Definitions

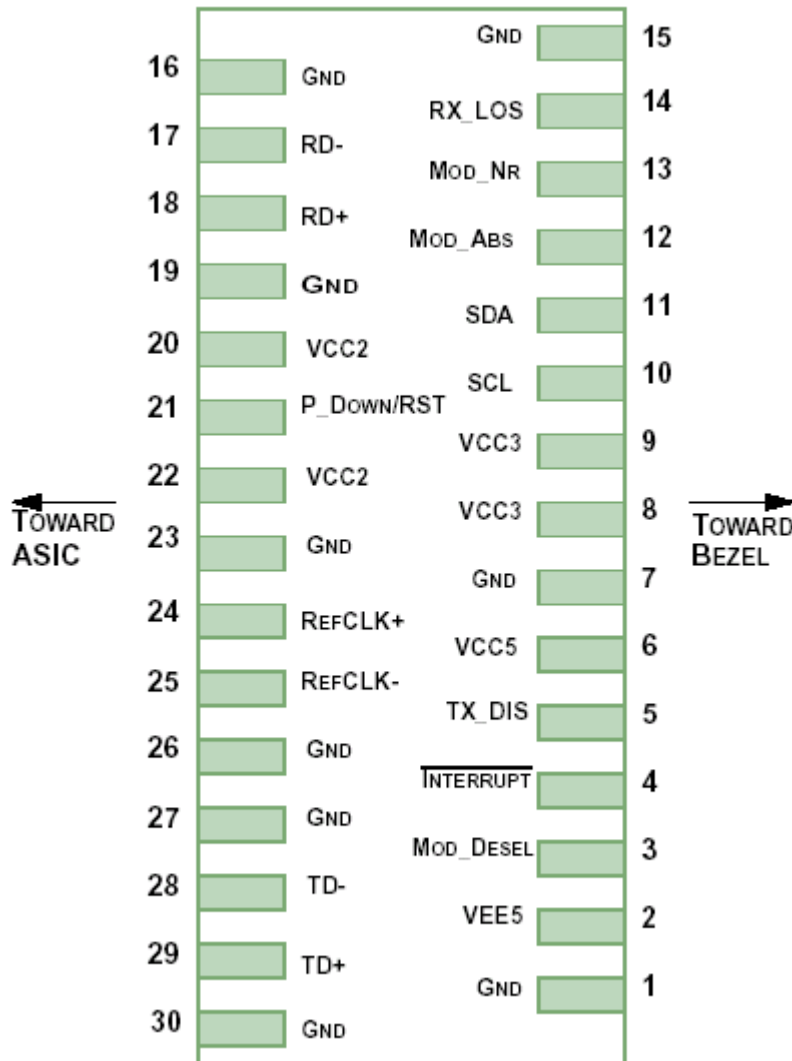

Figure 3, Pin View

Table 6–Electrical Characteristics

Pin	Logic	Symbol	Name/Description	Note
1		GND	Module Ground	1
2		VEE5	Optional -5.2V Power Supply (Not implemented)	3
3	LVTTL-I	Mod_Desel	Module De-select; When held low allows the module to respond to 2-wire serial interface	
4	LVTTL-O	Interrupt	Interrupt; Indicates presence of an important condition which can be read over the 2-wire serial interface	2

5	LVTTL-I	TX_DIS	Transmitter Disable; Turns off transmitter laser output	
6		V <sub>CC5</sub>	+5V Power Supply (Not implemented)	
7		GND	Module Ground	1
8		V <sub>CC3</sub>	+3.3V Power Supply	
9		V <sub>CC3</sub>	+3.3V Power Supply	
10	LVTTL-I/O	SCL	2-Wire Serial Interface Clock	2
11	LVTTL-I/O	SDA	2-Wire Serial Interface Data Line	2

12	LVTTL-O	Mod_Abs	Indicates Module is not present. Grounded in the Module	2
13	LVTTL-O	Mod_NR	Module Not Ready; Indicating Module Operational Fault	2
14	LVTTL-O	RX_LOS	Receiver Loss Of Signal Indicator	2
15		GND	Module Ground	1
16		GND	Module Ground	1
17	CML-O	RD-	Receiver Inverted Data Output	
18	CML-O	RD+	Receiver Non-Inverted Data Output	
19		GND	Module Ground	1
20		V <sub>CC2</sub>	+1.8V Power Supply (Not implemented).	3
21	LVTTL-I	P_Down/RST	Power down; When high, requires the module to limit power consumption to 1.5W or below. 2-Wire serial interface must be functional in the low power mode. Reset; The falling edge initiates a complete reset of the module including the 2-wire serial interface, equivalent to a power cycle.	
22		V <sub>CC2</sub>	+1.8V Power Supply (Not implemented)	3
23		GND	Module Ground	1
24	PECL-I	RefCLK+	Not used, internally terminated to 50ohm (100ohm diff).	4
25	PECL-I	RefCLK-	Not used, internally terminated to 50ohm (100ohm diff).	4
26		GND	Module Ground	1
27		GND	Module Ground	1
28	CML-I	TD-	Transmitter Inverted Data Input	
29	CML-I	TD+	Transmitter Non-Inverted Data Input	
30		GND	Module Ground	1

Notes:

1. Module ground pins GND are isolated from the module case and chassis ground within the module.
2. Shall be pulled up with 4.7K-10Kohms to a voltage between 3.15V and 3.45V on the host board.
3. The pins are open within module.
4. Reference Clock is not required

**Mechanical Diagram**

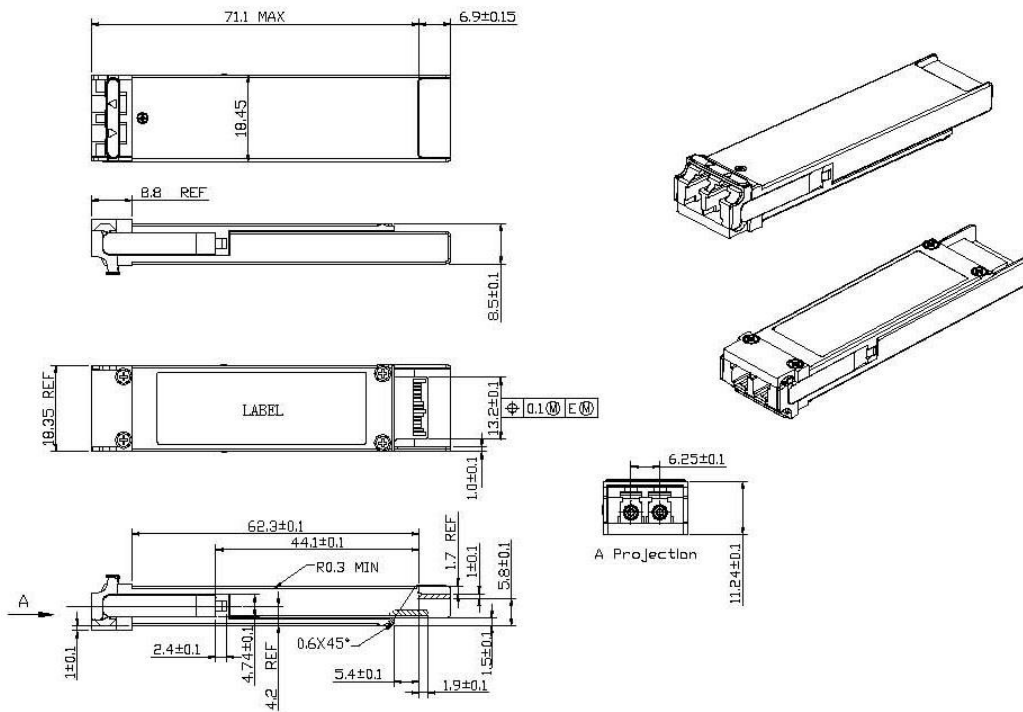

**Figure 4, Mechanical Diagram of XFP**



---

## Order Information

Table 7 – Order Information

Part No.	Application	Data Rate	Operating Temp	Distance
HOLS-XP154099-LD-CE	S-64.2b 10GBASE-ER	9.95G~11.3G	0 to +70°C	40km
HOLS-XP154099-LD-IE	S-64.2b 10GBASE-ER	9.95G~11.3G	-40 to +85°C	40km

## Warnings

**Handling Precautions:** This device is susceptible to damage as a result of electrostatic discharge (ESD). A static free environment is highly recommended. Follow guidelines according to proper ESD procedures.

**Laser Safety:** Radiation emitted by laser devices can be dangerous to human eyes. Avoid eye exposure to direct or indirect radiation.