

FEATURES

- Supports 9.95Gb/s to 11.3Gb/s bit rates
- 0 to 70°C operating case temperature for C-temp class, and -40 to 85°C operating case temperature for I-temp class,
- SFP+ package with duplex LC receptacle connector
- Hot-pluggable capability
- Single 3.3V power supply
- 1310nm DFB transmitter and high performance PIN receiver
- Up to 10km transmission distance over SMF
- Low power dissipation < 1W and no CDR inside
- SFI electrical interface
- Low EMI and excellent ESD protection
- Built-in Digital Diagnostic monitoring (DDM) function
- Class I laser safety standard IEC-60825 compliant
- RoHS-6 compliance

APPLICATIONS

- 10GBASE-LR/LW
- 10Gb/s Fiber Channel

STANDARDS

- Complies with SFP+ MSA (SFF-8431)
- Complies with SFF-8472 Rev 10.4
- Compliant with IEEE 802.3ae
- Complies with FCC 47 CFR Part 15, Class B
- Complies with 21 CFR 1040.10 and 1040.11 except for deviations pursuant to Laser Notice No. 50, dated June 24, 2007

ABSOLUTE MAXIMUM RATING					
Parameter	Symbol	Min.	Max.	Unit	Notes
Storage Ambient Temperature	T _{STG}	-40	85	°C	
Operating Case Temperature	T _c	0	70	°C	For C-temp class
	T _c	-40	85	°C	For I-temp class
Operating Humidity	OH	5	95	%	
Power Supply Voltage	V _{CC}	-0.5	3.6	V	
Receiver Damaged Threshold		4		dBm	

RECOMMENDED OPERATING CONDITION						
Parameter	Symbol	Min.	Typ.	Max.	Unit	Notes
Operating Case Temperature	T _c	0		+70	°C	For C-temp class
	T _c	-40		+85	°C	For I-temp class
Power Supply Voltage	V _{CC}	3.13	3.3	3.47	V	
Power Supply Consumption	P			1	W	For C-temp class
	P			1.5	W	For I-temp class
Date Rate		9.95		11.3	Gbps	
Data Rate Drift		-100		+100	PPM	

TRANSMITTER OPTICAL CHARACTERISTICS						
Parameter	Symbol	Min.	Typ.	Max.	Unit	Notes
Centre Wavelength	λ _c	1260	1310	1355	nm	
Spectral Width (-20dB)				1	nm	
Average Output Power		-7.2		0	dBm	Launched into SMF Fiber
Average Power of OFF Transmitter				-30	dBm	
Extinction Ratio	ER	3.5			dB	
Side Mode Suppression Ratio	SMSR	30			dB	
Transmitter and Dispersion Penalty	TDP			3.2	dB	

TRANSMITTER ELECTRICAL CHARACTERISTICS

Parameter	Symbol	Min.	Typ.	Max.	Unit	Notes
Data Input Differential Swing		180		700	mV	
Input Differential Impedance		85	100	115	Ω	
TX Disable	Disable	2		VCC	V	
	Enable	0		0.8	V	
TX Fault	Fault	2.4		VCC	V	
	Normal	0		0.4	V	

RECEIVER OPTICAL CHARACTERISTICS

Parameter	Symbol	Min.	Typ.	Max.	Unit	Notes
Operating Wavelength	λ_C	1260		1360	nm	
Sensitivity	SEN			-14.4	dBm	PRBS2 ³¹ -1@10.3125Gbps BER $\leq 1 \times 10^{-12}$
Saturation Optical Power	SAT	0.5			dBm	
LOS De-Assert	LOS _D			-18	dBm	
LOS Assert	LOS _A	-32			dBm	
LOS Hysteresis	HYS	0.5		5	dB	

RECEIVER ELECTRICAL CHARACTERISTICS

Parameter	Symbol	Min.	Typ.	Max.	Unit	Notes
Differential data output swing	V _{out}	350		850	mV	
Rx_LOS Output Voltage - High	High	2.4		V _{cc}	V	
Rx_LOS Output Voltage - Low	Low	0		0.4	V	
Output Rise Time, 20%~80%	TR			70	ps	PRBS2 ³¹ -1@10.3125Gbps
Output Fall Time, 20%~80%	TF			70	ps	PRBS2 ³¹ -1@10.3125Gbps

PIN DESCRIPTION

PIN	Name	Description	Notes
1	V _{EE} T	Transmitter Ground	
2	TX_Fault	Transmitter Fault Indication	Low: normal; High: abnormal
3	TX_Disable	Transmitter Disable	Low: transmitter on; High: transmitter off
4	SDA	SDA	The data line of two wire serial interface
5	SCL	SCL	The clock line of two wire serial interface
6	MOD_ABS	Module Absent	Connected to V _{EE} T or V _{EE} R in the module
7	RS0	Not Connected	
8	RX_LOS	Loss of Signal	Low: signal detected; High: loss of signal
9	RS1	Not Connected	
10	V _{EE} R	Receiver Ground	
11	V _{EE} R	Receiver Ground	
12	RD-	Inv. Received Data Out	AC-coupled, CML
13	RD+	Received Data Out	AC-coupled, CML
14	V _{EE} R	Receiver Ground	
15	V _{CC} R	Receiver Power	
16	V _{CC} T	Transmitter Power	
17	V _{EE} T	Transmitter Ground	
18	TD+	Transmit Data In	AC-coupled, CML
19	TD-	Inv. Transmit Data In	AC-coupled, CML
20	V _{EE} T	Transmitter Ground	

PIN OUT DRAWING (TOP VIEW)

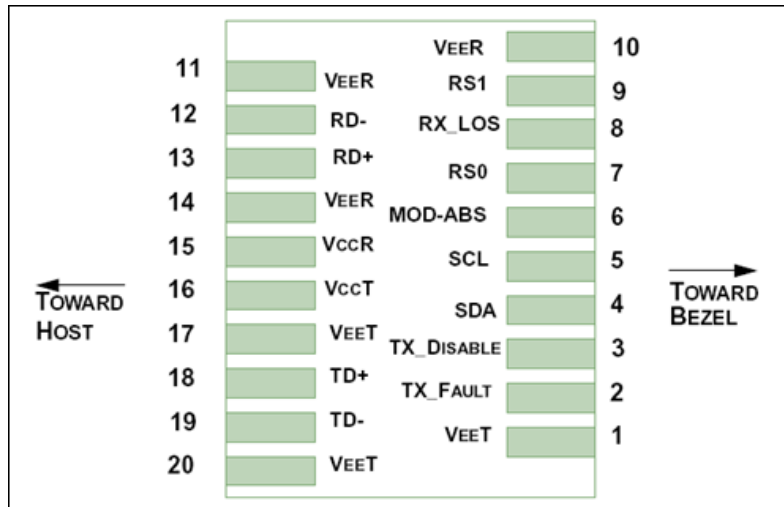

Figure 1 Pin Out Drawing (Top view)

TYPICAL INTERFACE CIRCUIT

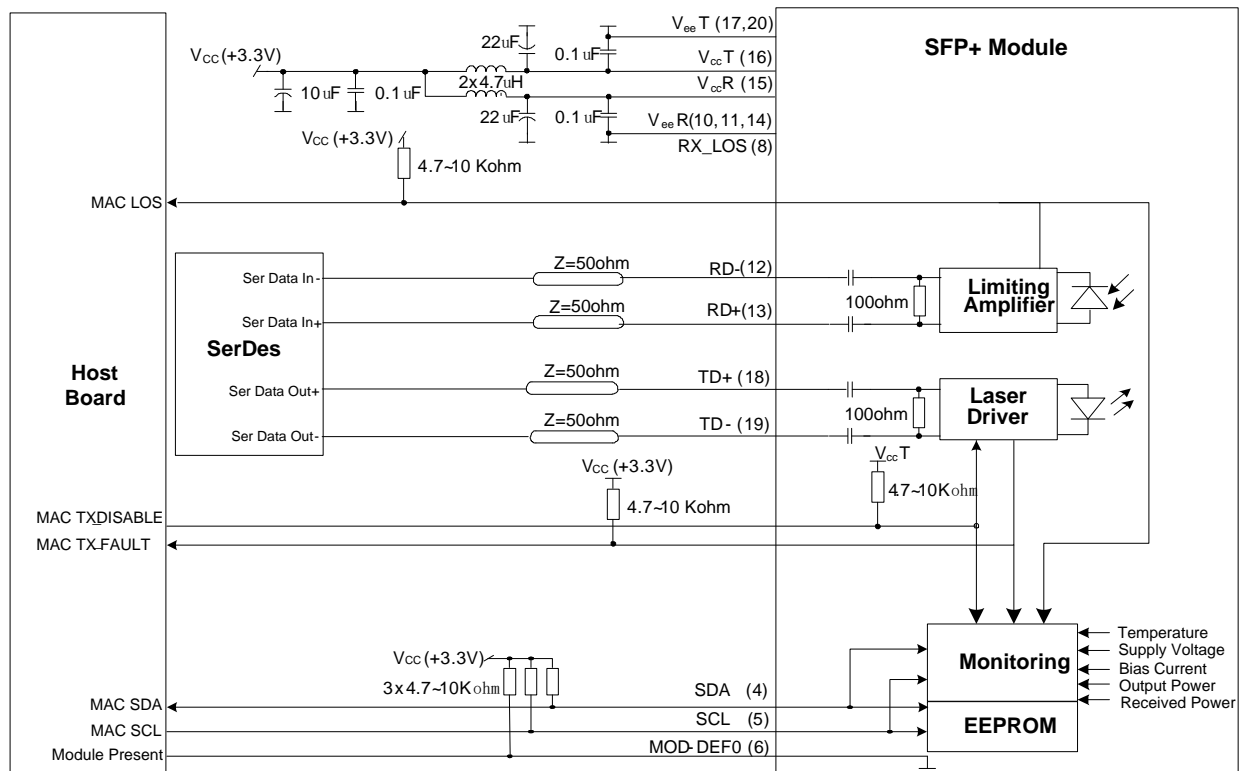

Figure 2 Typical Interface Circuit

PACKAGE OUTLINE

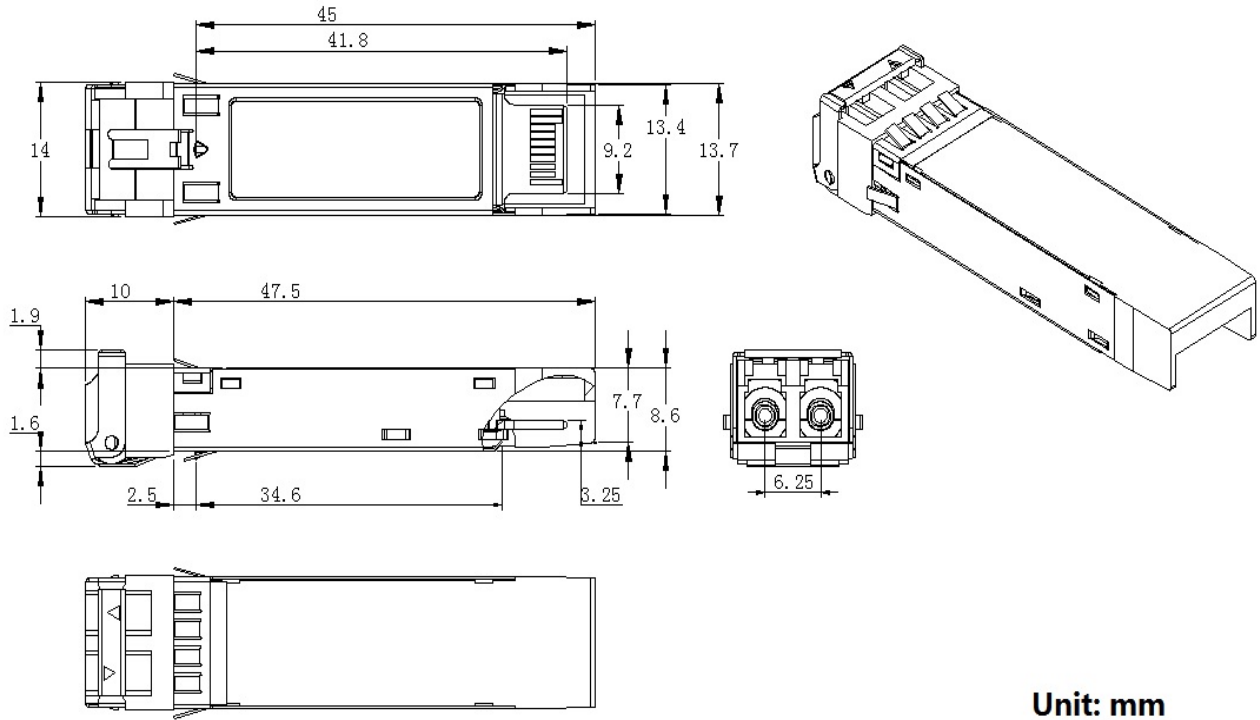

Figure 3 Package Outline

EEPROM INFORMATION

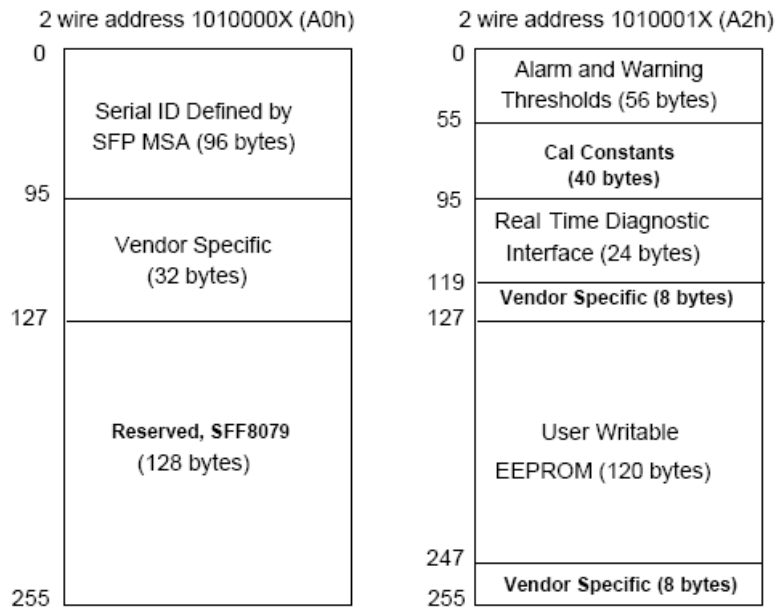

Figure 4 EEPROM Memory Map Specific Data Field Descriptions

DIGITAL DIAGNOSTIC MONITORING INTERFACE

Parameter	Range	Accuracy	Calibration	NOTES
Temperature	-40 to 85°C	±3°C	Internal	LSB: 1/256C
Voltage	2.97 to 3.63V	±3%	Internal	LSB: 0.1mV
Bias Current	0 to 100mA	±10%	Internal	LSB: 2uA
TX Power	-8 to +1dBm	±2dB	Internal	LSB: 0.1uW
RX Power	-16 to +1dBm	±2dB	Internal	LSB: 0.1uW

ORDERING INFORMATION

PN	Temperature Rating	Unit
HOLS-PP131077-LD-CD	0 ~ 70	°C
HOLS-PP131077-LD-ID	-40 ~ 85	°C

WARNINGS

- Handling Precautions: This device is susceptible to damage as a result of electrostatic discharge (ESD). A static free environment is highly recommended. Follow guidelines according to proper ESD procedures.
- Laser Safety: Radiation emitted by laser devices can be dangerous to human eyes. Avoid eye exposure to direct or indirect radiation.